

Book of services

WHO WE ARE

iLumTech has more than 15 years of experience in the research and development of luminaires and all connected design and engineering services. Thanks to wide-ranging experience, NDA approach, and access to the most advanced technical and development equipment, iLumTech can offer flexible and professional support for a large variety of customers.

The quality of our services is guaranteed by the capability and education of our international team of more than 60 designers and engineers, who receive regular training on the latest trends and standards. The sustained improvement of our laboratories and technologies also ensures that our customers will be satisfied with the implementation of the latest trends in the provided services and development.

WHAT WE OFFER

- FLEXIBLE AND PROFESSIONAL DESIGN AND SERVICE SUPPORT FOR CUSTOMERS FROM VARIOUS INDUSTRIES
- STABLE AND RELIABLE PARTNERSHIP FOR CUSTOMERS AND THE DEVELOPMENT OF THEIR PRODUCTS
- INTERNATIONALLY TRUSTED PROVISION OF NEW SOLUTIONS AND INNOVATIONS
- A FOUNDATION FOR THE DEVELOPMENT OF A UNIQUE NETWORK OF TECHNOLOGICALLY FUTURE-ORIENTED COMPANIES
- A LISTENING EAR FOR CUSTOMER NEEDS THAT WE SATISFY BY USING THE LATEST TECHNOLOGIES AND FOLLOWING THE LATEST TRENDS

FULL LUMINAIRE DEVELOPMENT

We provide solutions for luminaire manufacturers that cover everything from concept to release of the product to the market. Within the framework of these solutions, we deliver comprehensive services across industrial, optical, thermal, electronic, and mechanical design, all of which are supported by excellent supply-chain management, full system testing, and prototyping.

DESIGN & ENGINEERING SERVICES

We are home to experienced experts from many fields who enable us to support customers with a wide range of individual design and engineering services. If you require industrial design, optical design, thermal evaluation, electronic solutions or even the development of entire products, our team can provide a perfectly tailored solution. We also offer mechanical engineering and customisation services that ensure that even the smallest details are taken care of.

LABORATORY SERVICES

We have some of the best-equipped laboratories in Europe and can provide customers with an array of optical, thermal, electronic, and mechanical tests side-by-side with other services. A particular advantage of this is that we can perform tests on final prototypes, assuring customers of positive results throughout development and during certification.

FURTHER OEM SUPPORT

We offer customers the option to continue with the manufacture of developed luminaires, optical systems, and electronic solutions at trusted facilities close to our company.

PROPRIETARY COMPONENTS & DEVICES FOR THE LIGHTING MARKET

We bring to the market a range of unique lighting control devices under the brand name Connected Lighting, as well as original Optical Solutions and LED Units. All are suitable for a variety of customers including lighting and components manufacturers, distributors, wholesalers, installation companies, and end-users.

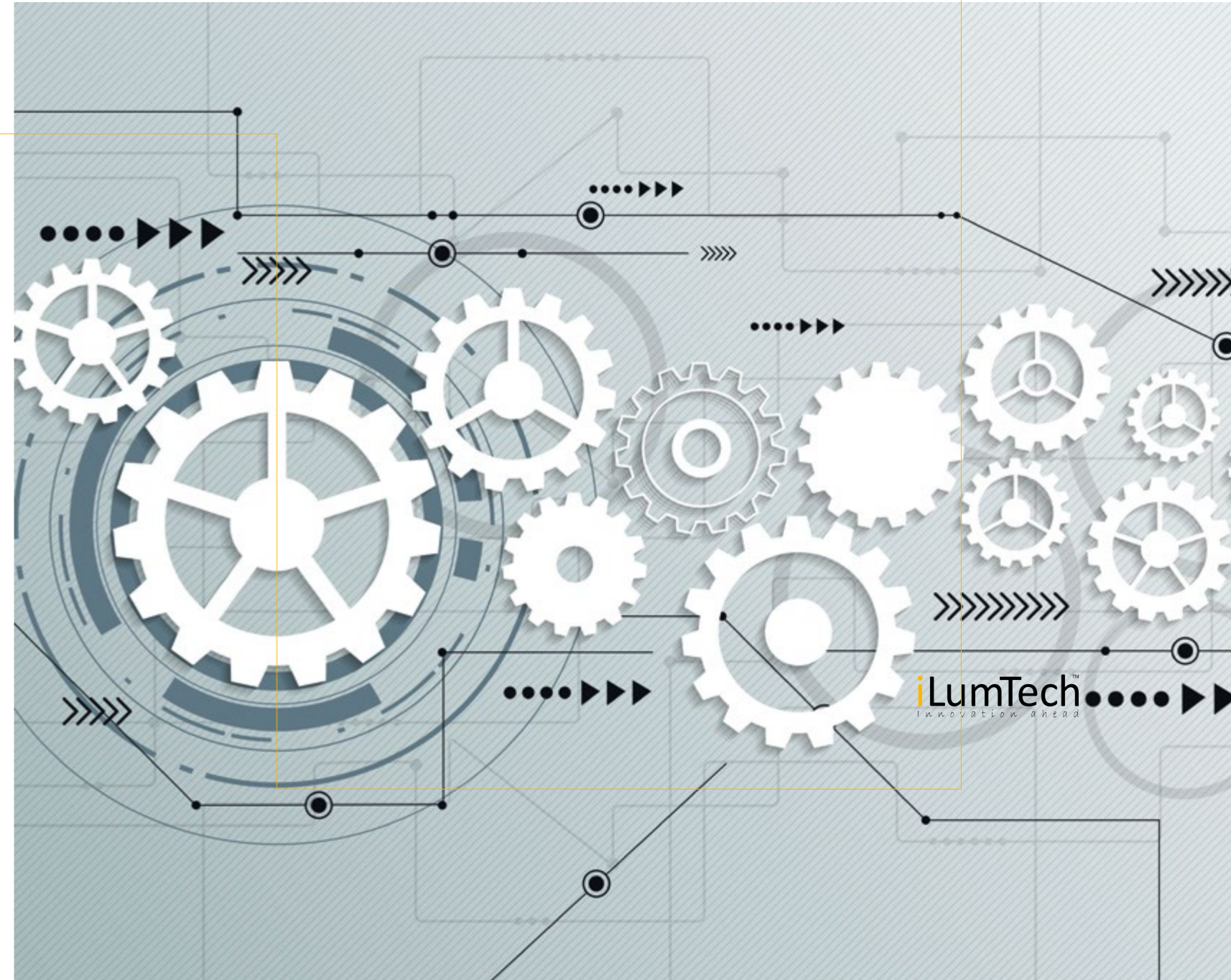

FULL LUMINAIRE DEVELOPMENT

FULL LUMINAIRE DEVELOPMENT

PRODUCT DEVELOPMENT REQUEST

TECHNICAL & COMMERCIAL NEGOTIATION
& AGREEMENT

DEVELOPMENT STAGES

PRODUCT COMPLETION & CERTIFICATION

AFTER-SALES SERVICES

FULL LUMINAIRE DEVELOPMENT

Not every company has the time, capacity or resources to develop a new luminaire in-house. That's where we can help. We make it our business to support your business. By listening to your needs and understanding your business's marketplace, we can best apply our knowledge and experience to develop a final product that will give you a competitive advantage, save your time, and reduce your costs.

“Perfection has to do with the end product,
but excellence has to do with the process.”

Jerry Moran

PRODUCT DEVELOPMENT REQUEST

PRODUCT DEVELOPMENT REQUEST

TECHNICAL & COMMERCIAL NEGOTIATION & AGREEMENT

DEVELOPMENT STAGES

PRODUCT COMPLETION & CERTIFICATION

AFTER-SALES SERVICES

The first input we have from you, as a customer, is the specification of your request. So that we know exactly what you want, we will ask you to fill in a product development form. A deeper understanding of your specifications, aims, and market positioning will be gained from direct discussion, where we can also get to know each other a little better.

LET US KNOW WHAT YOU NEED

- WHAT KIND OF PRODUCT DO YOU WANT?
- WHERE WILL IT BE USED?
- DO YOU HAVE A MARKET AND PRICE IN MIND?
- HOW FAST DO YOU NEED IT?
- WHAT ARE YOUR PRODUCTION REQUIREMENTS AND VOLUMES?
- WHAT ABOUT DOCUMENTATION AND CERTIFICATION?

TECHNICAL REQUIREMENTS

To help us evaluate your request and prepare price offers for the product itself, and for engineering and tooling services if required, we need to understand exactly what you wish to develop from a technical point of view, including the intended application of the luminaire.

MATERIAL & SHAPE SPECIFICATION

The first step in defining a product is selecting the kind of shape and colour you'd like and the material you want it to be made from. Also, tell us your requirements for mounting and other parameters such as IP/IK ratings and operating ambient temperatures?

OPTICAL REQUIREMENTS

The optics of a luminaire are core to its functional and commercial success. We need to know what LIDC you need, illumination requirements, whether you want direct, indirect or combined flux, and if there are specific glare considerations to take into account. To precisely define these parameters, we will ask you for a desired lumen output, UGR value, beam angle, luminance value, and what type of optics you'd prefer.

LED REQUIREMENTS

Surely you also have in mind what type of LEDs you would like to include in your product. What CCT and CRI do you need? How strict are your MacAdam step requirements? Do you have a desired wattage, and what type of system efficacy would you like to achieve?

ELECTRONIC PARAMETERS

We are happy to include any type of control system you wish into your product. This is not limited to dimming and emergency units, but also includes the option to incorporate independent control of direct and indirect flux, RGB lighting, and Tunable White (we have a range of Tunable White modules that could be interesting to you). Just let us know what norms the luminaire must fulfil, the electric class required, if there are flammability considerations, and if there are any specific tests or certificates you wish us to provide.

COMPONENT SPECIFICATION

If you have any particular requirements regarding components you want to use, just let us know in advance, and we will be sure to smoothly implement them into the design.

COMMERCIAL CONDITIONS

Before investing in the development and engineering of a new product, it is important to set a target market price, which will define your limits in terms of total cost of creation. There are many other commercial conditions to also consider, such as warranty, launch date, required volume, and the number of prototypes you would like during development. We can also continue with the manufacture of your product in partnership with trusted local businesses.

VISUALS

Please share with us any materials you have that will help us fully understand your vision. For example, show us your current and previous products, what has inspired you, the benchmarks you wish to meet, and even your own hand drawn sketches. This will speed up initial discussions and ensure there are no misunderstandings about exactly what you want.



TECHNICAL & COMMERCIAL NEGOTIATION & AGREEMENT

PRODUCT DEVELOPMENT REQUEST

TECHNICAL & COMMERCIAL NEGOTIATION & AGREEMENT

DEVELOPMENT STAGES

PRODUCT COMPLETION & CERTIFICATION

AFTER-SALES SERVICES

Successful partnerships and products depend on good preparation and continued open communication. To avoid unnecessary issues at a later stage, we begin development with a meeting where we discuss our in-depth offer that includes detailed specification of services and schedules.

WHAT OUR OFFER INCLUDES

- AN INITIAL DESIGN PROPOSAL
- A PRICE OFFER BASED ON ENGINEERING AND TOOLING REQUIREMENTS
- A DESCRIPTION OF THE DEVELOPMENT STAGES
- SCHEDULES AND MILESTONES
- EVALUATION OF ADDITIONAL COSTS
- A DEVELOPMENT CONTRACT
- A PRODUCTION CONTRACT, IF REQUIRED

PRODUCT SPECIFICATION & PROPERTIES DEFINITION

We will help you complete the product definition form. All technical issues are evaluated, re-evaluated and optimised during project meetings, at which the responsible persons for your project from each R&D department and the commercial team will be present. During the product definition phase, we will encounter our first obstacles, to which we will endeavour to find suitable solutions to prevent delay later in the development process. Every discussed detail will be recorded in your product definition documentation and sent to you to double check. This gives you added assurance that the foundation we build upon is precisely according to your wishes.

COST & TIME SCHEDULE EVALUATION

Based on the final definition, we will prepare a time schedule containing project milestones. You can discuss your feelings about the project based on the documentation provided at these milestones. You will also receive a cost evaluation, which is the quote divided according to development costs and tooling expenses. Commercial conditions, including the price and payment conditions, along with the schedule, are part of the overall development contract as well as the signed product development form.

DEVELOPMENT CONTRACT

The result of the technical and commercial negotiation and agreement process is the final development contract and confidentiality agreement. Here, all conditions and the commencement date of development are stated.



DEVELOPMENT STAGES

PRODUCT DEVELOPMENT
REQUEST

TECHNICAL & COMMERCIAL
NEGOTIATION & AGREEMENT

DEVELOPMENT STAGES

PRODUCT COMPLETION &
CERTIFICATION

AFTER-SALES SERVICES

Effective development of an LED product requires a comprehensive understanding of multiple engineering disciplines, typically light sources, optics, thermal management, controllers, additional power sources, and packaging. These parts must be seamlessly integrated together to ensure optimal performance and cost, and that the product meets customer needs. We have the engineering resources to provide complete turnkey product development that harmonises all these parts.

NOW THE ENGINEERING BEGINS

- INDUSTRIAL DESIGN
- OPTICAL DESIGN
- THERMAL DESIGN
- ELECTRONIC DESIGN
- MECHANICAL ENGINEERING
- PROTOTYPING
- MEASUREMENT AND TESTING
- TOOLING
- PRODUCTION (ON REQUEST)

ENGINEERING

Luminaire development begins with industrial design: a process of creating 3D designs using 3D modelling software that allows us to implement any adjustments you wish immediately. We can also prepare non-functional mock-ups for better analysis of the aesthetic features of the product. After the industrial design is confirmed, we will continue further with optical, thermal and electronic design, and finally with mechanical engineering. Optical and thermal design is based on the preparation of simulations and selection of materials and cooling systems. The departments must work closely together to fine-tune proposals according to achieved simulated values. Electronic design involves creation of PCB designs and suggestion of the most suitable components for electronic schemes. If desired, we can also implement suitable software and interfaces, or even design new ones, to enable simple and flexible control of your product. And lastly, the mechanical engineers prepare sheet metal, die cast, and extrusion designs appropriate to the type of product. They must ensure that all desired mechanical properties are provided, especially in the case of requested IP/IK protection.

FINAL DOCUMENTATION

Once the engineering stages are complete, we will provide you with comprehensive documentation that acts as the base for creation of prototypes to be tested in our laboratories.

PROTOTYPING & EVALUATION

What type of prototype we use for testing and evaluation depends on the kind of luminaire and what materials it is made from. We have the possibility to use 3D printing to produce a prototype that can be tested as a final product from an optical point of view. If the prototype is produced from milled aluminium, it is also possible to test the thermal, electronic and mechanical aspects. All results are shared with you and evaluated against the product definition form.

TOOLING

As soon as you give us approval of the final documentation and prototype, we will move on to the tooling stage. This involves the production of die casts, extrusion tools, or injection moulds. Tool production is regularly controlled by us to avoid further issues, including the evaluation of tool prototypes, and any necessary optimisation. The final tools are also measured and the results sent to you and assessed by our engineers.

PROJECT PREPARATION

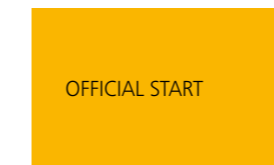

DESIGN

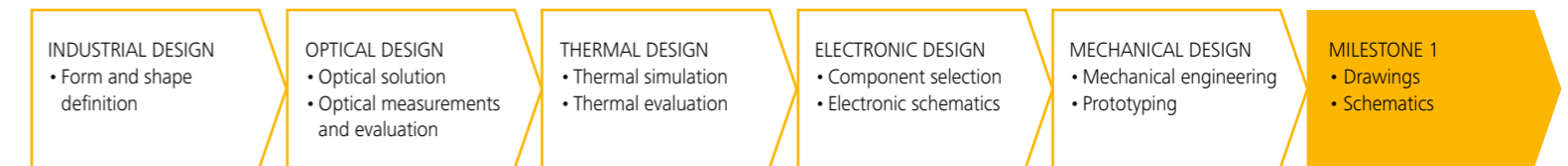

PROTOTYPING



PRE-SERIES, KICK-OFF & CERTIFICATION

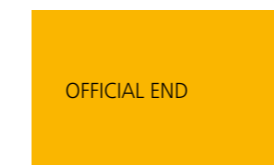
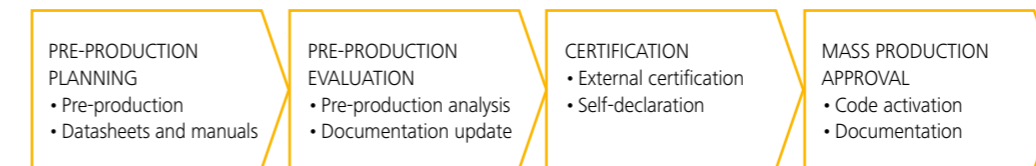

PRODUCT COMPLETION & CERTIFICATION

PRODUCT DEVELOPMENT
REQUEST

TECHNICAL & COMMERCIAL
NEGOTIATION & AGREEMENT

DEVELOPMENT STAGES

**PRODUCT COMPLETION &
CERTIFICATION**

AFTER-SALES SERVICES

The development process is nearing its end, but there is still work to do. We welcome you to join us at the release meeting or pre-series for a final check of the details of your product, and its assembly and packaging. In addition to the already provided final technical documentation, we can support you with production and assembly manuals, and any third party certification.

DEVELOPMENT ENDS AND THE LIFECYCLE BEGINS

- PRE-SERIES FOR PRODUCTION EVALUATION
- MANUFACTURING ON REQUEST IN COOPERATION WITH TRUSTED, LOCAL BUSINESSES
- OEM MANUFACTURE ACCORDING TO YOUR WISHES
- MANAGEMENT OF THIRD PARTY CERTIFICATION

THIRD PARTY TESTING

After finalisation and testing of the prototype, if certification by a third party is required, the product is sent to the appropriate certification laboratory. As we perform all tests in-house beforehand, the possibility that the product fails any official laboratory test is eliminated. This ensures that the final release of your product to the market is not unnecessarily delayed.

RELEASE FROM DEVELOPMENT

Once we have the test reports and certificates issued by the certification laboratories, the next step is to release the product from R&D. During the release meeting, the final prototype, test reports, and samples are compared to the product definition form. If the results are satisfactory, the product is released from development following a defined release protocol that needs to be signed by all responsible parties. At this point, all datasheets and instructions are already prepared additional to the internal codes and a final Bill of Materials (BOM). When the product is officially released from development, you are also supplied with full technical documentation. At this stage, you can check the documentation and any necessary corrections will be made. Final technical documentation is only provided once all issues have been resolved.

PRE-SERIES

Between the development and mass production of the product, there is a step called pre-series. At this point, production engineers check the luminaire and its assembly based on the prepared technical documentation and instructions. If any corrections need to be made before the product enters mass production, this is the time when they are implemented. Once the pre-series phase is completed, the product is released to mass production.

RELEASE TO MASS PRODUCTION

Now that pre-series is complete and all necessary certification in place, the product can be released to mass production. You may have your own manufacturing services in place, or we can organise this for you in cooperation with trusted local business. We will discuss this along with forecasted volumes with you during the development stages in order to secure suitable delivery times and organise spare parts on stock. Produced luminaires will be packaged as requested with labels and barcodes.

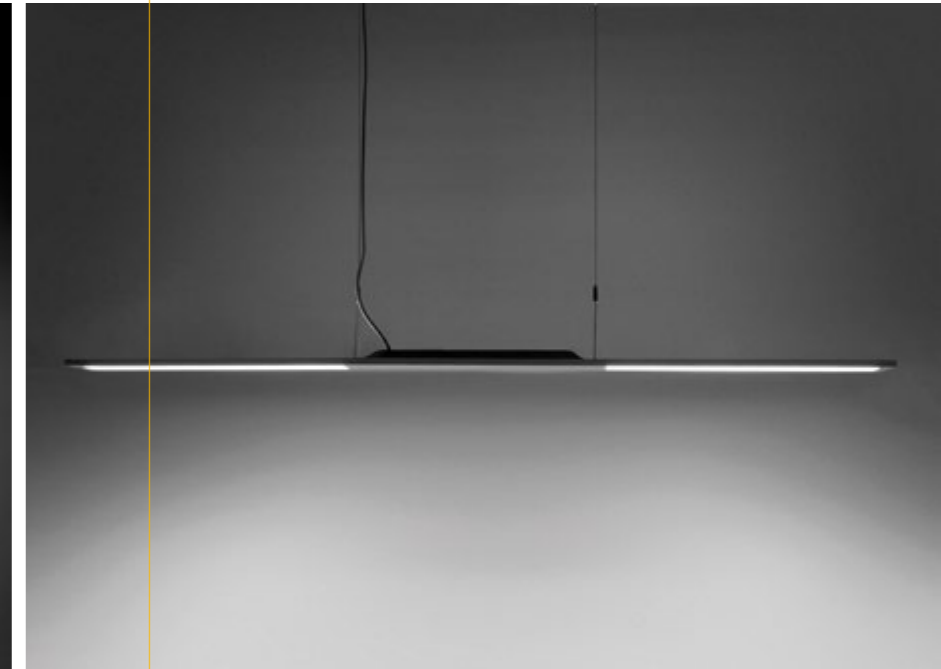

AFTER-SALES SERVICES

- PRODUCT DEVELOPMENT REQUEST
- TECHNICAL & COMMERCIAL NEGOTIATION & AGREEMENT
- DEVELOPMENT STAGES
- PRODUCT COMPLETION & CERTIFICATION
- AFTER-SALES SERVICES**

Developing a product is one thing. But we all know how hungry customers are for each new development, and how often they request something not standardly available. You can take all this in your stride because we will also take care of your products into the future. We are partners.

WE WILL CONTINUE WITH YOU EVEN AFTER MANUFACTURE

- PRODUCT UPDATES
- PRODUCT OPTIMISATION AND CUSTOMISATION
- FULL LUMINAIRE FAMILY DEVELOPMENT
- COST EVALUATION
- TECHNICAL SUPPORT
- MANUFACTURE

CUSTOMISATION

We can adjust your existing products according to specific request, covering everything from modification of the mounting, optical system, dimensions and construction of the luminaire, to the adding of air slots, sensors, and emergency kits.

OPTIMISATION

New methods for the production of materials and solutions are innovated faster than ever, which inevitably means that older ones become obsolete or more costly. If your products contain such elements, your production costs may get too high and your profit margin too low. It is also possible that the materials and solutions you use exhibit qualities that are not necessary for your application, yet you still pay for them. We know that finding the most suitable materials and processes can mark the difference between success and failure, so will help you find the most appropriate, viable and practical options for your products, resulting in simplified construction, more efficient assembly, reduced costs, and higher profits.

PRODUCT UPDATES & AFTER-SALES SERVICES

We don't only develop products, we can also provide continued support through product updates. As technologies progress at a rapid rate, especially in the case of LED, it is necessary to modify products during their lifecycle to ensure they are current. We will arrange generation updates to keep your product one step ahead of the competition by changing the technologies used or modifying aspects of the design to meet the latest standards. To ensure that we remain as flexible as possible in terms of updating, we will offer you the choice of upgrading to the latest generation LEDs or of keeping those originally used at a reduced cost. The choice is entirely up to you.



PRODUCT DEVELOPMENT & ENGINEERING SERVICES

INDUSTRIAL DESIGN

DESIGN RESEARCH
CONCEPT & PRODUCT DESIGN
MOCK-UPS
PRODUCT & CORPORATE PROMOTION
DESIGN GALLERY

OPTICAL DESIGN

OPTICAL SYSTEM DEVELOPMENT
REFLECTOR & PARABOLIC LOUVRE DESIGN
REFRACTOR & DIFFUSER DESIGN
LIGHTING DESIGN
LENS DEVELOPMENT & TOOLING

THERMAL DESIGN

THERMOMECHANICAL SIMULATION
CFD ANALYSIS
THERMOGRAPHY
LED LUMINAIRE LIFETIME PREDICTION

ELECTRONIC DESIGN

HARDWARE DESIGN
FIRMWARE DESIGN
SOFTWARE DESIGN
LABWARE DESIGN
ELECTRONIC DESIGN CONSULTANCY
THE TUNABLE WHITE STORY

MECHANICAL ENGINEERING

SHEET METAL DESIGN
ALUMINIUM DIE CAST
& EXTRUSION DESIGN
ALUMINIUM FORGING
MECHANICAL ANALYSIS

INDUSTRIAL DESIGN

A good designer establishes a strong visual hierarchy. As Saint-Exupery said: "A designer knows he has achieved perfection not when there is nothing left to add, but when there is nothing left to take away." Yes, to do a good design is not only about what, but also why, and how. After all, design is not just making things pretty; it's also making them work well. iLumTech designers work with all other departments to assure that the final product works, can be manufactured, and will be successful and unique.

"I think it's the responsibility of a designer to try to break rules and barriers."

Gianni Versace

DESIGN RESEARCH

DESIGN RESEARCH

CONCEPT & PRODUCT DESIGN

MOCK-UPS

PRODUCT & CORPORATE PROMOTION

Every company wants extraordinary products. But how to create them? Based on a full understanding of your specific needs, we can precisely define targets and provide fresh ideas that we then transform into viable and inimitable high-class industrial products.

WHY IS DESIGN RESEARCH IMPORTANT?

- IT SUPPORTS THE CREATION OF UNIQUE PRODUCTS
- YOU FULLY UNDERSTAND THE COMPETITION, AND SO CAN DO THINGS BETTER
- YOU KNOW ALL THE TRENDS AND ARE READY FOR THE FUTURE
- YOUR SALES SUCCESS IS GUARANTEED IN ADVANCE

STYLE DEFINITION

To support your unique corporate identity through design, we assess your visual style and analyse how it will define the creative process. This acts as the base for product definition, brand development, and portfolio expansion.

COMPETITOR RESEARCH

By performing comprehensive market research, we can create an overview of current relevant competitor strategies for selected product groups. This underpins every new product development by providing necessary context and contrast for product and market definition.

DESIGN STRATEGY

For a product to be successful, it must find its niche in the market. The shapes, colours, and materials chosen should follow the desires of the target customer. To help you find out what your customer really wants, we will guide your product focus and marketing strategy, which will in turn support the setting of release dates. Our knowledge of the lighting industry and competition further helps us to understand the design requirements of different customer groups and markets from a geographical and social point of view – advice we are happy to share with you.



CONCEPT & PRODUCT DESIGN

DESIGN RESEARCH

CONCEPT & PRODUCT DESIGN

MOCK-UPS

PRODUCT & CORPORATE PROMOTION

Product design covers all the pre-production processes that lead to a fully functional prototype. By combining our creative cross-industry expertise with software analysis, CAD virtual reality simulation, and effective manufacturing processes, we can ensure lean production and the reliability and quality of the developed product.

WHY RELY ON OUR DESIGNERS?

- WE KNOW THE LIGHTING MARKET
- WE UNDERSTAND HOW TO CONNECT WISH WITH REALITY
- WE WORK CLOSELY WITH OPTICAL, ELECTRONIC, AND MECHANICAL ENGINEERS
- WE LISTEN AND AIM WHERE YOU ARE AIMING
- WE ARE OPEN-MINDED

PROJECT DEFINITION

We will select the aesthetic style and features of the product based on its basic technical definition, market and customer profiling, and technological and user trends.

CONCEPT INNOVATION

This is a process that includes mind mapping and critical discussion that allows us to combine and develop understanding of product needs, creation of initial concepts, and selection of methods for delivering satisfactory results. We approach every product design with an open mind and focus on creative and uninhibited thinking.

PRODUCT DESIGN

The next step is to go into more detail by assessing and selecting the best shapes, colours, materials, and textures in order to meet specific needs. This is the most critical step in the process and often includes provision of several proposals that can be evaluated against key indicators to more closely define the basic features of the final product. Through close cooperation with our mechanical engineers, we can keep our feet on the ground when preparing design proposals, while also letting our "designer's fantasy" take flight. The result is a truly unique, interesting and producible product.

DESIGN MANAGEMENT

In close partnership with our product managers, we can support and evaluate your product strategy and set-up achievable and measurable goals that take your product all the way from concept to successful release to the market.

PRODUCT OPTIMISATION & ENHANCEMENT

Thanks to connection with the mechanical engineering department and our knowledge of manufacturing processes, we can support other companies with product optimisation and enhancement. Do you have manufacturing difficulties and need a design modified, or would you like to reduce costs? Whatever you need, we will find a way to satisfy.

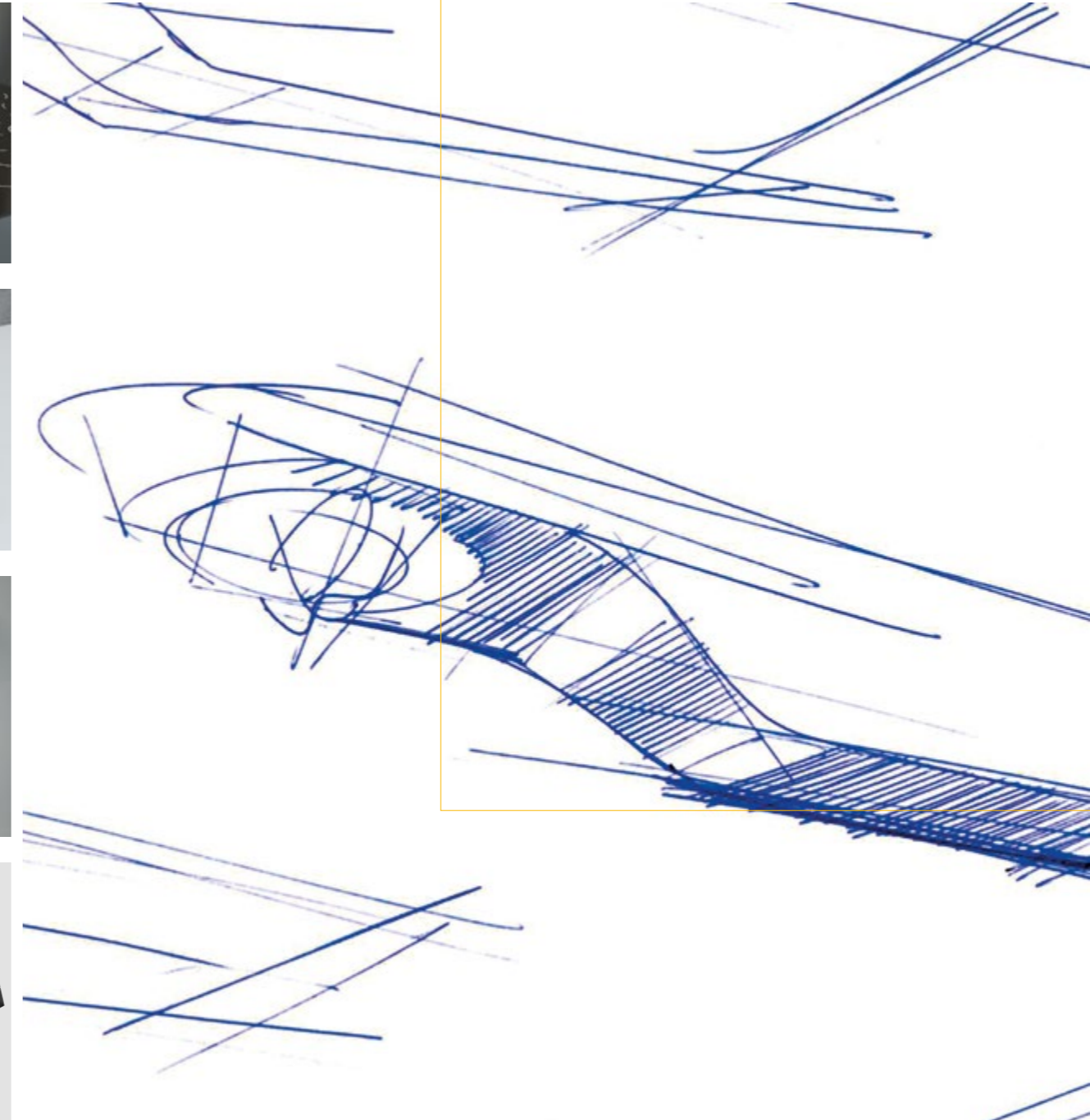
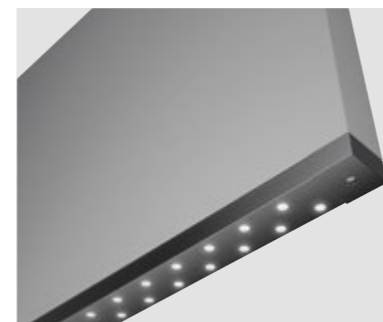
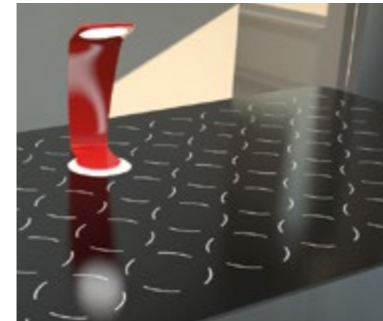

MOCK-UPS

DESIGN RESEARCH

CONCEPT & PRODUCT DESIGN

MOCK-UPS

PRODUCT & CORPORATE PROMOTION

Nothing can replace the experience of a physical product model. We can create mock-ups that simulate the physical appearance of a product, and those that simulate its functionality, using a wide range of methods from clay modelling and vacuum forming to hand-modelling techniques.

MOCK-UPS WITHIN UNBEATABLE TIMESCALES

- CLAY MODELS
- PAPER MOCK-UPS
- STYROFOAM MOCK-UPS
- FUNCTIONAL MOCK-UPS

PHYSICAL APPEARANCE MOCK-UPS

Physical appearance mock-ups are suitable for shape and proportion assessment, material, surface texture, and colour evaluation, and to support component selection.

FUNCTIONAL MOCK-UPS

Functional mock-ups are a working model of the product and do not adhere to aesthetic design details. They are very useful throughout the entire product development process to guide the enhancement and optimisation of designs, especially during the early stages when fundamental decisions need to be made about basic parameters.

APPLICATION MOCK-UPS

One of the best ways to promote your product is to show how it looks and works in a realistic setting. We can develop and construct application mock-ups at various scales, from mobile models with integrated miniature products and simulated functionality to full-scale models of spaces with installed product prototypes.



PRODUCT & CORPORATE PROMOTION

DESIGN RESEARCH

CONCEPT & PRODUCT DESIGN

MOCK-UPS

PRODUCT & CORPORATE PROMOTION

Many quality products do not make it to the market because they lack the right promotion. Let us support you by providing everything from interactive full-scale models suitable for location testing and photo shoots to animated presentations and even complete retail solutions. Our team will apply the full breadth of its experience to make your product visible on the market.

WHAT SUPPORTS PROMOTION?

- A SUITABLE MARKETING STRATEGY
- ORIGINAL PACKAGING
- VISUALISATIONS AND PRESENTATIONS
- MOBILE MODELS FOR SITUATION SIMULATION

MARKETING STRATEGIES

Based on our market and competitor research, industry experience, and in-depth knowledge of your product, we will help you develop suitable targeted, local, and global marketing strategies for your product, and even for your brand.

PROMOTIONAL VISUALISATIONS & PRESENTATIONS

Using specialised CAD rendering programmes and post-production techniques, we can create realistic product visualisations suitable for a range of uses. We can also develop presentations in static, animated, 3D or video format according to your needs.

EXHIBITION STAND DESIGN CONSULTANCY

Having significant experience in the development and construction of exhibition stands, we offer design consultancy to support the best presentation of brands and products at trade shows. Stand designs are tailored to the type of exhibition, purpose of your presence there, and will follow closely your brand and market image.

PACKAGING DESIGN

Eyes buy. Packaging design is crucial to the sales success of every product. We can provide for you any packaging design you need, suitable for retail. To do this, we rely on specialised software that allows us to create a wide range of variants and possibilities. All you need to do is select which you think will most encourage your customers to buy.

VIRTUAL MODEL CONSTRUCTION

3D virtual models are usually requested to aid in shape assessment, construction evaluation, or as a way to measure several key indicators. Just let us know what format and quality you need, and we can prepare models that will help development move forward. Such models may also be used for other purposes such as for inclusion in animations and presentations. Let your imagination go, and rely on us to make presentation of your business easier.



DESIGN GALLERY

In addition to playing a functional role, doors also play an aesthetic role and should follow the style, architecture, and design of a building, room, vehicle or space. Therefore, we can say that doors have both a utilitarian and aesthetic element. Door manufacturers need to find ways to improve the fulfilment of both of these elements if they want to deliver to the market original and interesting solutions. One way to do make doors more attractive to customers is to combine them with lighting.

OPEN THE DOOR TO A NEW WORLD OF LIGHT

The most common function of the door is its ability to be locked. In order to know if the door is locked, we can use a subtle light that will switch on after locking. The same function can also be used in the case of interior doors where privacy is needed, for example, on bathroom doors.

Another possibility is to use differentiating lighting effects on doors. In this case, the number or name of the room can be illuminated. The use of various colours, shapes, and lighting techniques will also support the aesthetic element of the door's design. Thanks to this, the user can even reduce the number of other auxiliary devices such as emergency signs and room names.

Finally, each door needs to have a door handle. Why not also extend the possibility of illumination to this element? We suggest that a door handle could be equipped with an ambient light sensor, allowing for a small light to be switched on automatically in low light levels so that people can easily find their way without needing to turn on a bigger light.

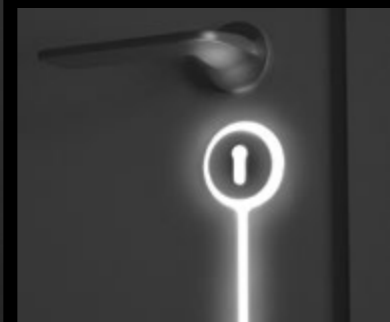
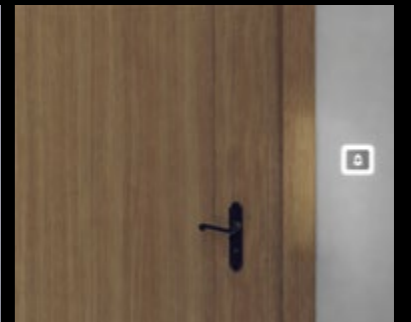
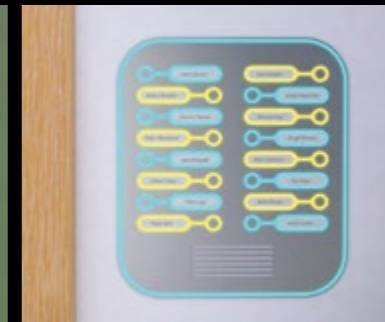
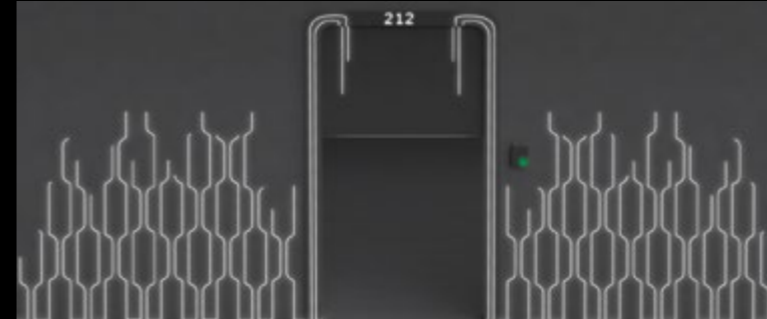

DESIGN GALLERY

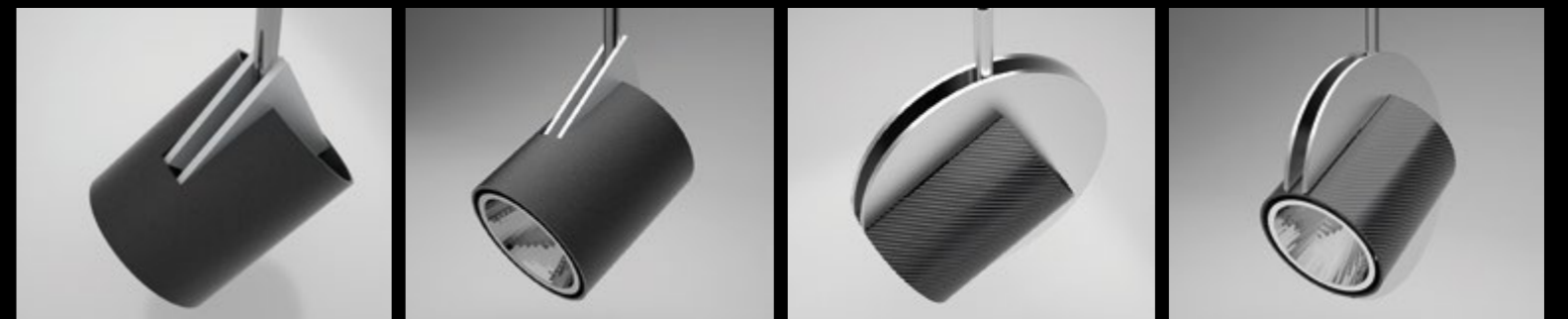
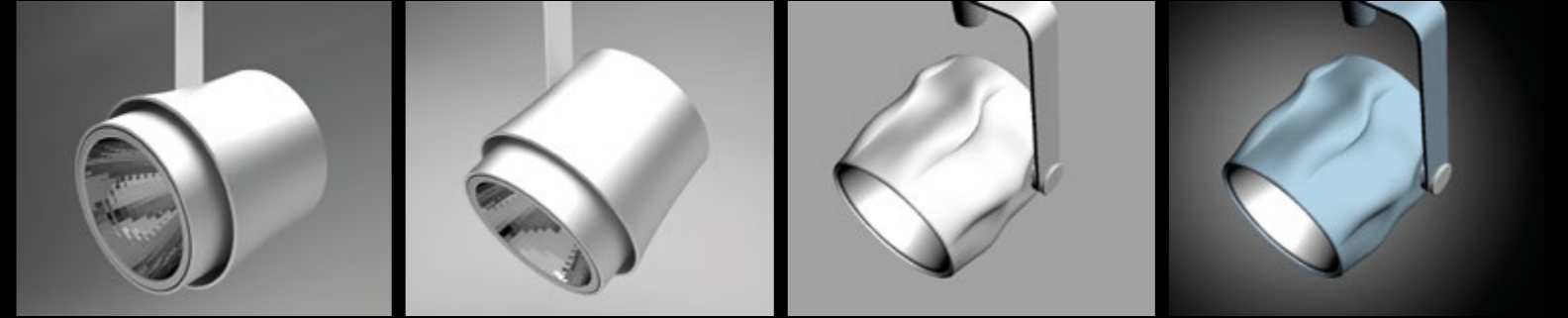

DESIGN GALLERY

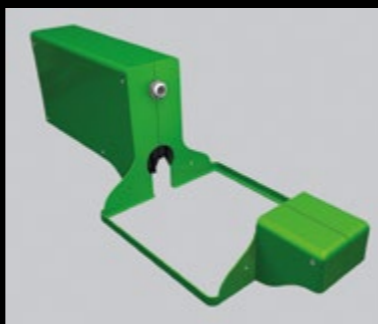
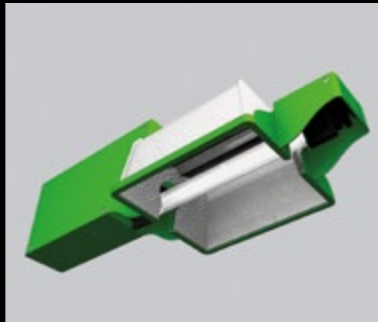
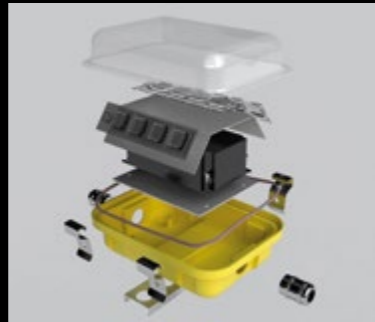
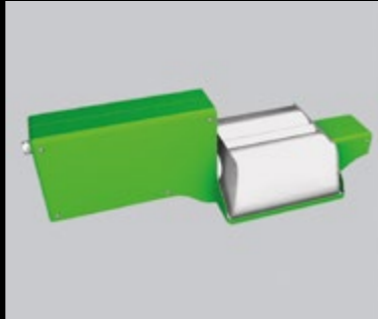
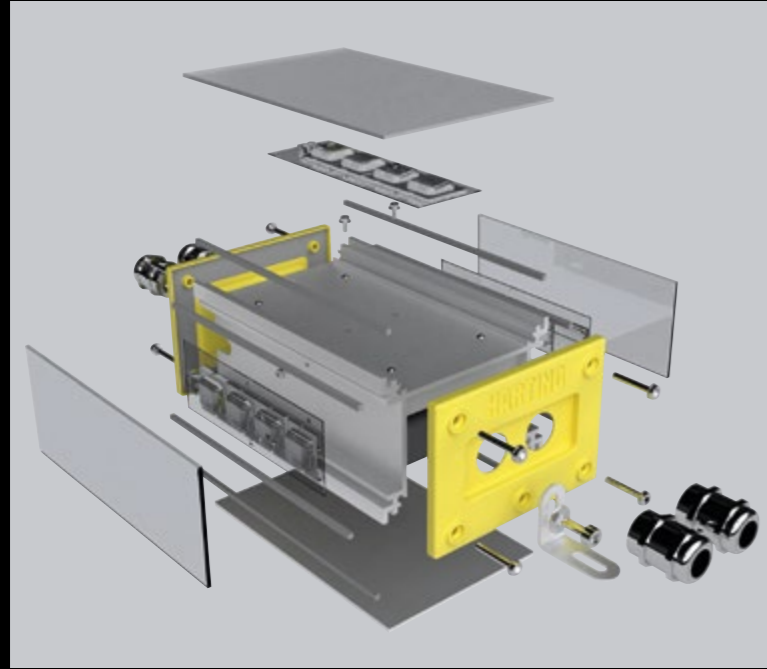

OPTICAL DESIGN

It is always possible to develop a product using commercially available optical systems. However, if you really want to be a manufacturer of successful, unique, and interesting luminaires while maintaining control over costs, there is only one way to proceed that makes sense: to develop and produce tailored lens or reflector systems. We have the skills and experience to support you throughout the entire process, from design through to tooling and production.

“Music is the arithmetic of sounds as optics is the geometry of light.”

Claude Debussy

OPTICAL SYSTEM DEVELOPMENT

OPTICAL SYSTEM DEVELOPMENT

REFLECTOR & PARABOLIC LOUVRE DESIGN

REFRACTOR & DIFFUSER DESIGN

LIGHTING DESIGN

Optimal luminaire performance is only achieved if effective and appropriate optical parts are selected and refined to meet the specific needs of each product. We have access to the latest development technologies as well as having vast practical experience and theoretical knowledge, all of which are applied to every product that passes through our hands.

WHAT DOES OPTICAL DESIGN INCLUDE?

- SELECTION OF THE RIGHT LIGHT DISTRIBUTION
- EVALUATION OF THE MOST SUITABLE OPTICAL PARTS
- COMBINING OF DIFFERENT OPTICAL SYSTEMS
- CHECKING THE SUITABILITY OF COMMERCIALY AVAILABLE PARTS
- DESIGN OF TOTALLY NEW OPTIONS
- TESTING AND OPTIMISATION OF PARTS
- CLOSE PROFESSIONAL COOPERATION WITH ALL OTHER ENGINEERING DEPARTMENTS

OPTICAL PART SELECTION

There are several types of optical part to choose from, each with its own strengths and each suitable for different uses. Reflectors and parabolic louvres change the light emitted from the light source by reflection and are made from materials with high reflectance, with parabolic louvres also serving to shield light sources from view at key angles. Refractors and lenses change the light distribution of a light source by refraction and are made of materials with direct transmission. Diffusers change the light distribution mostly by diffusion and are made from materials with light diffusing properties. The choice of the most suitable optical parts for each product is the first step in the design of a tailored optical system.

SPECTRAL & LUMINANCE ANALYSIS

When designing an optical system, it is vital to know what light parameters are required and to ensure that the product under development meets those needs. This includes knowledge of the luminance, LIDC, Colour Rendering Index (CRI), and Correlated Colour Temperature (CCT) of the light source. We can perform the spectral and luminance analysis of light sources, which allows us to save both time and money by creating and analysing mathematical models rather than needing to produce expensive working prototypes.

OPTICAL SYSTEM OPTIMISATION

Based on in-depth spectral and luminance analysis, we can optimise any part of an optical system in accordance with international standards. Virtual prototyping, simulation, optimisation, and creation of photo-realistic renders of precision illumination applications is done using LightTools®, one of the best-known software applications used for optical analysis. The software has adapted solid modelling technology to accommodate the inherent accuracy required to simulate the ray paths of light as they traverse through and within optical elements and mechanical structures. In terms of optical design and analysis, it provides us with unlimited possibilities.

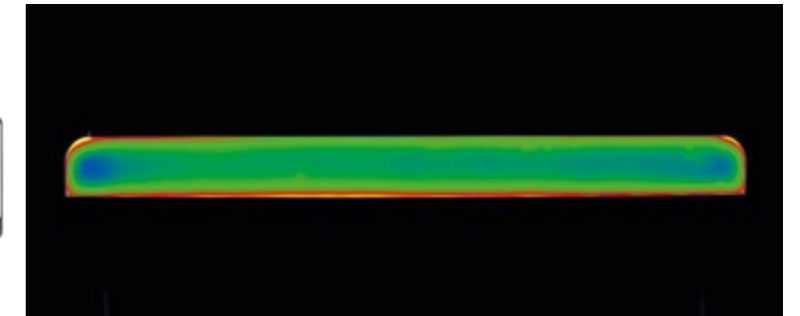

REFLECTOR & PARABOLIC LOUVRE DESIGN

OPTICAL SYSTEM DEVELOPMENT

REFLECTOR & PARABOLIC LOUVRE DESIGN

REFRACTOR & DIFFUSER DESIGN

LIGHTING DESIGN

There are many different types of reflector to use to help create a desired light distribution: conical, elliptical, zonal, hyperbolic, freeform, etc. The task of the optical designer is to select the most suitable option and optimise it to meet your specific requirements.

BASIC INPUTS NEEDED FOR REFLECTOR DESIGN

- APPLICATION, AMBIENT CONDITIONS, AND STANDARD INSTALLATION PARAMETERS
- 3D STP FILE OF THE LUMINAIRE
- DIMENSION LIMITATIONS
- TYPE OF LED TO BE USED
- REQUIRED LIGHTING PARAMETERS
- REQUESTED LIDC
- DESIRED EFFICIENCY AND UGR VALUE
- PRODUCTION TECHNOLOGIES TO BE USED
- SPECIFIC MATERIAL AND SURFACE FINISH PROPERTIES

REFLECTOR SELECTION

Selecting the most suitable reflector depends on the type of luminaire it will be applied to and where that luminaire will be used. For example, spotlights are generally equipped with faceted conical reflectors whereas linear luminaires used in industrial settings tend to be equipped with a simple reflector with a metallic or white surface finish. We have an extensive library of materials from which to choose to make sure that the reflector used will perform as needed.

REFLECTOR OPTIMISATION

In order to provide the exact LIDC needed, we will check with you about various details of the space the luminaire will be used in. We will also ask you if there are any specific lighting parameters that must be provided. The answers allow us to define optical parameters and modify the reflector accordingly. For this purpose, we have developed our own LIDC Optimiser tool, which is used together with LightTools®.

REFLECTOR DESIGN

Reflective optics use reflection to capture the light emitted by a light source, in most cases in the form of parabolic, hyperbolic or elliptical reflectors. It is most difficult to create freeform reflectors, which are able to precisely deliver light to the right place and with the right intensity. This will be a key point in our future reflector designs: that there be no limitation to the optical design of reflective optical parts. We work closely with the mechanical engineers at this stage as they create the mechanical design of the reflectors in CATIA, which in turn acts as the base for tooling and production. It is therefore very important for us to know if you have any technology specifications regarding the production of the reflector, as this will influence material selection and possibly even the shape of the reflector.

OPTICAL RESEARCH

We have developed a 60° reflector suitable for spot luminaires, which is available from our portfolio.

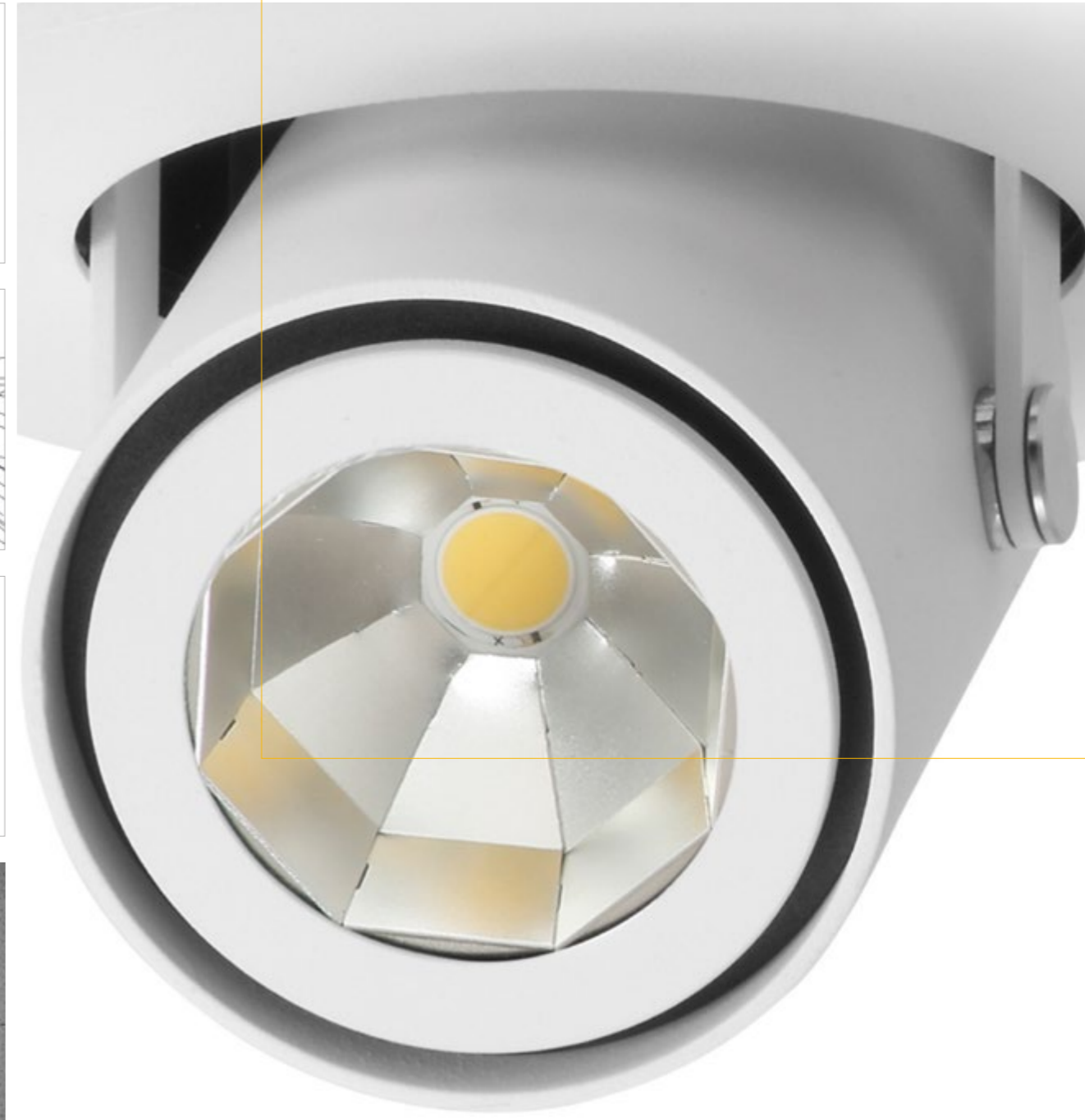
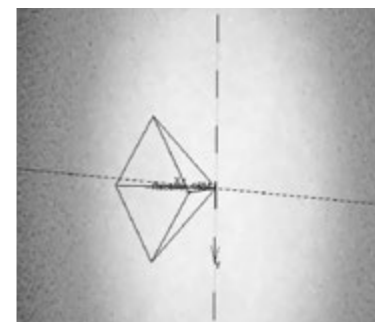
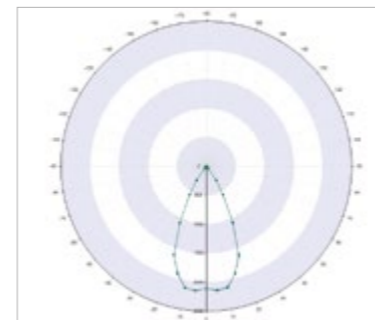
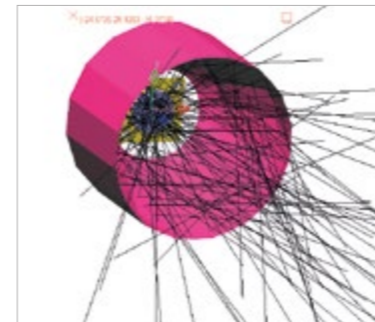

REFRACTOR & DIFFUSER DESIGN

OPTICAL SYSTEM DEVELOPMENT

REFLECTOR & PARABOLIC LOUVRE DESIGN

REFRACTOR & DIFFUSER DESIGN

LIGHTING DESIGN

If you want a uniform light distribution with a specific LIDC, the most suitable optical system for you will be one based on refraction, which is the modification of a light ray's movement through a material. There are two types of refractive optical part: refractors and diffusers. The choice of the best option for your needs is the job of experienced lighting designers.

WHEN IS A REFRACTOR OR DIFFUSER THE BEST CHOICE?

- YOU NEED HOMOGENOUS AND UNIFORM ILLUMINATION
- THERE ARE LOW UGR REQUIREMENTS
- TO COVER LEDS
- YOU WANT SOFT, DIFFUSED LIGHT

REFRACTOR & DIFFUSER SELECTION

The most commonly used refractive materials are in fact referred to as diffusers as their refractive properties cause diffusion of the transmitted light. There are also diffusers that do not use refraction but are rather made of materials with light diffusing properties. It is difficult to understand the advantages and disadvantages of each type of refractive or non-refractive diffuser, especially in terms of its application in a specific setting. We are experienced in making these choices and can help you understand which best suits your needs.

REFRACTOR OPTIMISATION

It is possible to modify a refractive material in order to achieve a desired LIDC; however, this is an incredibly difficult task that requires a high level of expertise. To help us with this process, we have developed our own LIDC Optimiser software, which helps us determine the precise LIDC needed for each application, and provides calculations we can use as a base for optical optimisation.

REFRACTOR DESIGN

There are a variety of refractive optics used in illumination systems. In this group, we can find lenses, arrays, prisms, pillow optics and also protective covers. Based on this great flexibility, we are able to create any refractor design according to customer needs.

OPTICAL RESEARCH

In addition to the design and optimisation of optical systems and parts, we also put a great deal of energy into optical research. We have developed a nano-diffuser that can be used as a replacement for standard optical parts such as prismatic diffusers, louvres, and reflectors. Our nano-diffuser is a thin PMMA plate applied with opto-mechanical nano-structures that control light distribution by modifying the surface or volume of the material. The optical relief is invisible as the dimensions of the structures is in nanometres (microns). The bitmap design consists of million of pixels that represent structures (Fresnel lenses) that can focus, collimate, partially collimate, and diverge incoming light beams in the same way as conventional lenses, but, thanks to the size, allow for more precise control of the light and so greater optical efficiency. By placing the nano-diffuser at different distances from the LEDs, the LIDC can be modified. Our nano-diffusers are available from the iLumTech portfolio.

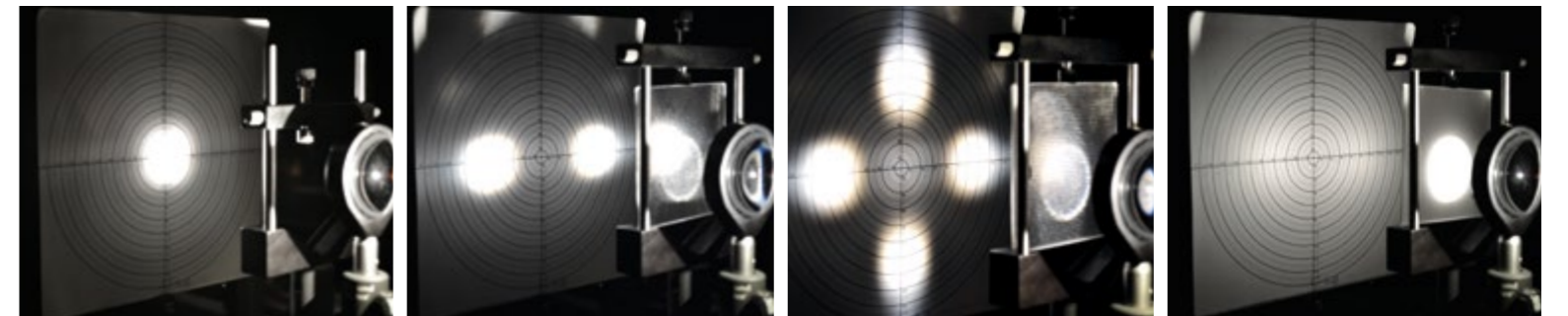
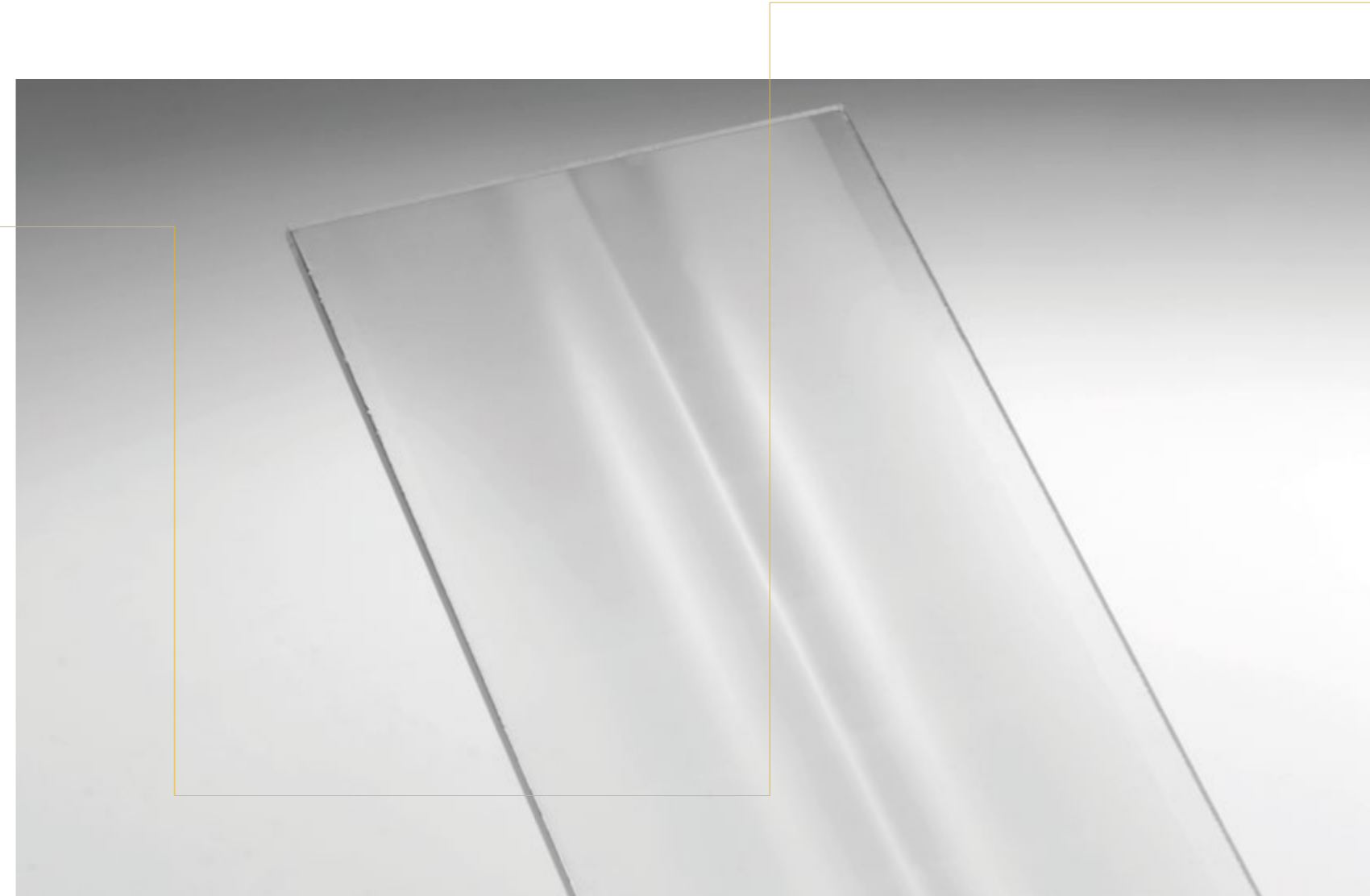

LIGHTING DESIGN

OPTICAL SYSTEM DEVELOPMENT

REFLECTOR & PARABOLIC
LOUVRE DESIGN

REFRACTOR & DIFFUSER DESIGN

LIGHTING DESIGN

Lighting design services form an integral part of each product development process as it helps us to ensure that it will fit the designated application. It is a standard part of optical development and performance assessment to test a luminaire in an appropriate practical-use simulation. As a result, we have great experience in checking how products suit the requirements of an application, and in proposal of suitable solutions – services we extend to you also.

LIGHTING DESIGN OUTPUTS

- LIGHTING CALCULATIONS
- ENERGY SAVING CALCULATIONS
- 3D VISUALISATIONS
- CAD PRODUCTION

LIGHTING DESIGN

Our optical designers have in-depth understanding of lighting project requirements and can help you achieve the correct illumination – whether it is inspirational lighting effects for your hotel, house or garden, or assured visual acuity throughout a town and its streets. We use DIALux in combination with a range of proprietary tools to make sure you get the most suitable lighting possible. Outputs include 3D visualisations, lighting calculations, energy saving calculations, and CAD production.

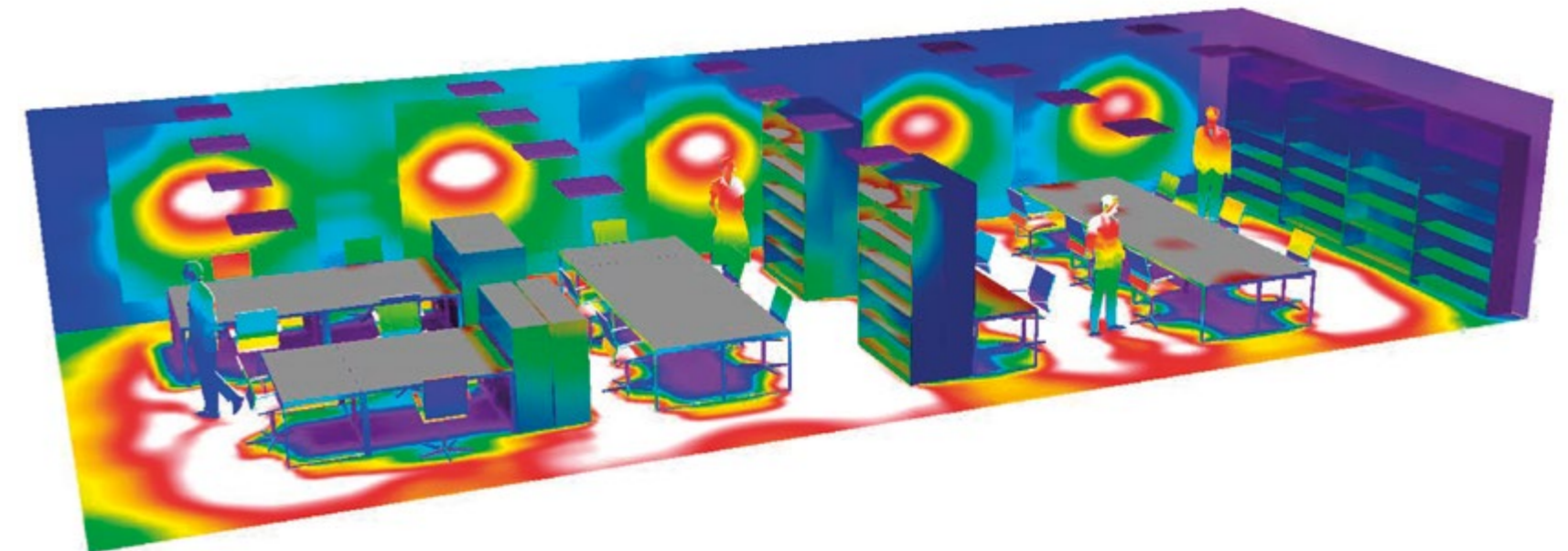
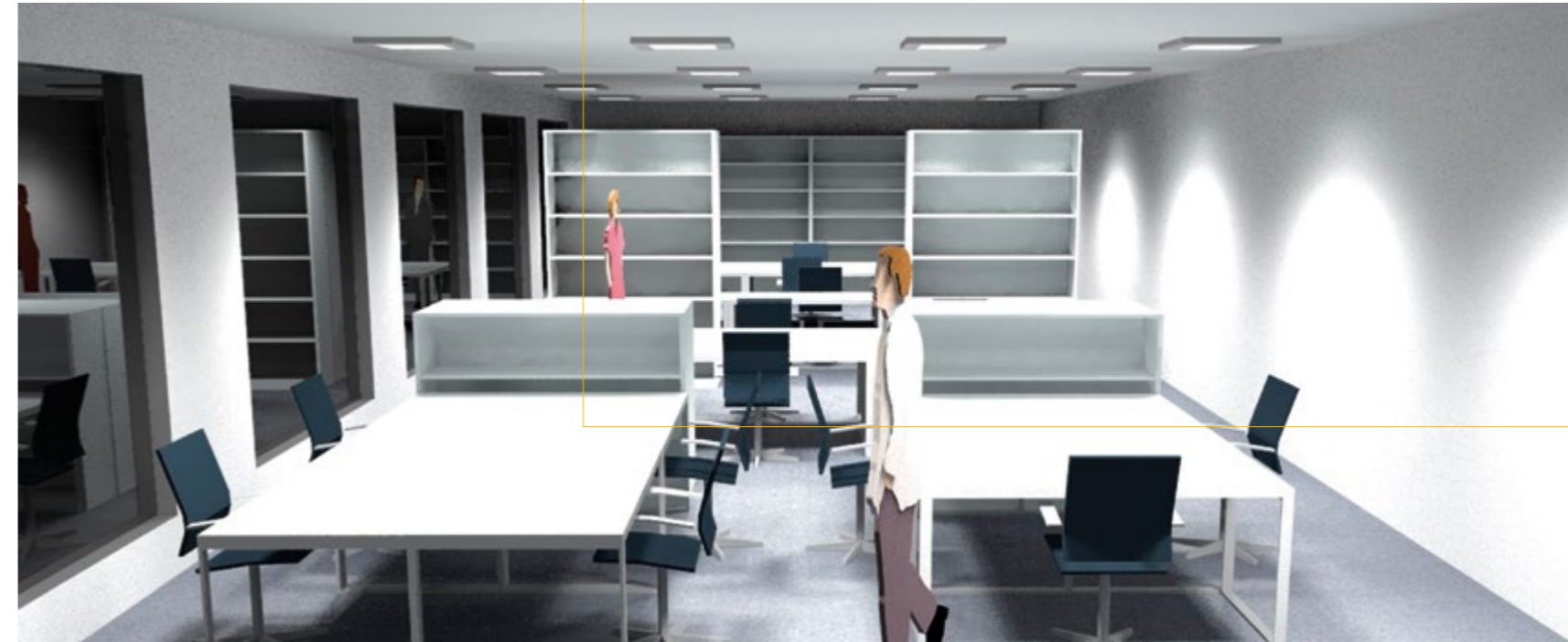

LENS DEVELOPMENT & TOOLING

Lenses have become a standard part in optical design, especially in LED luminaires. They offer incredible flexibility of design and application as well as improved mechanical and optical parameters compared to conventional optical technologies.

OPTICAL DESIGN

A simple lens is made from a transparent material that transmits and refracts light and converges or diverges the beam. Lenses allow us to achieve lighting parameters other optical systems can't. For this reason, multi-lenses are often used in modern LED street luminaires where norms stipulate very strict illumination requirements. We have experience in developing lenses according to request.

LENS OPTIMISATION

Lenses are commonly positioned directly on the LED, and come in many shapes and sizes. Only experienced and knowledgeable optical engineers know how to determine the best lens for each product. For highly demanding street lighting luminaires, we have developed our own Street Light Configurator, which allows us to combine up to four different lenses at various angles to provide a desired LIDC.

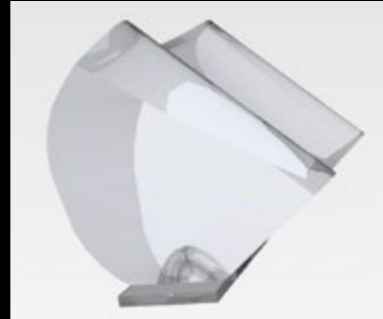

MECHANICAL DESIGN

Once an optical design is finalised, we will prepare the mechanical design within which the optics will be placed. This is usually done on the basis of a customer PCB and luminaire, whether real or to be developed. The mechanical design also includes the design of requested packaging. Next, we create a prototype that enables us to assess the suitability of the design for tool production, and the mechanical fit of the lenses within the luminaire in preparation for IP testing and rating. We use various proven external partners with specialist experience in this field for the creation of such prototypes. All prototypes are evaluated by us based on precise photometric measurements.

TOOL PRODUCTION

The third step is the preparation of production tools. The creation of die cast moulds can take several weeks, and for this we cooperate with top-class manufacturers from the automotive industry. We will take care of this entire process by visiting manufacturers, organising the output quality and, if needed, arranging for tool corrections. We check the performance of all tools before approving them and sending them to the production location. The customer is also provided with a certificate of ownership.

LENS MANUFACTURE

We can go on to organise the full production of optical parts on request, including tool setup and calibration. Thanks to collaboration with external manufacturers located close to our site, we can provide smooth and efficient logistics and communication hand in hand with stress-free service at unbeatable prices.

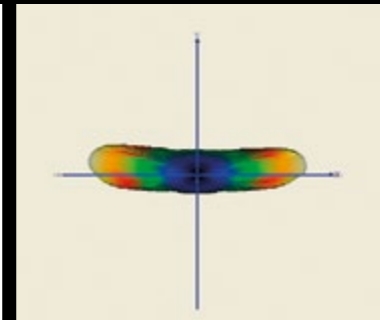
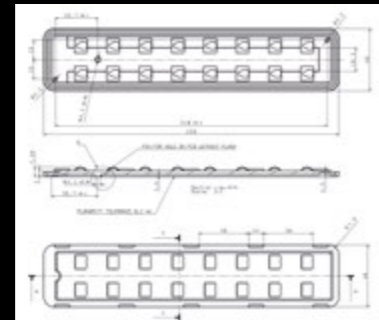
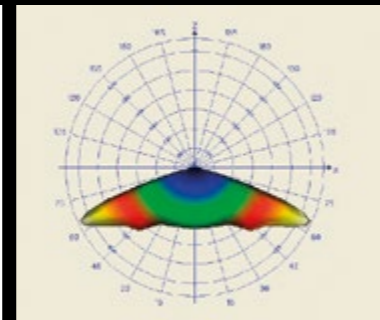
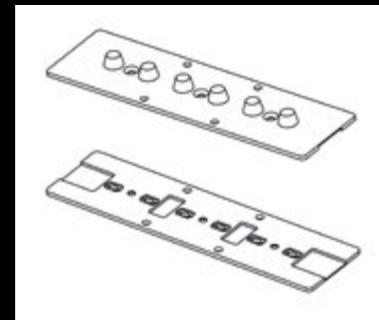

THERMAL DESIGN

The most important part of thermal design is thermal simulation, without which many thermal solutions fail to deliver a required performance for an application. By using SOLIDWORKS (module FloEFD R20), we are able to verify and compare thermal designs, optimise them for given luminaires, and so ensure that your thermal design will work.

Whether you have come to us for full luminaire development or wish to increase the performances of a current product, we are at hand and ready to share our testing and simulation experience.

“Nothing in life is certain except death, taxes,
and the second law of thermodynamics.”

Seth Lloyd

THERMOMECHANICAL SIMULATION

THERMOMECHANICAL SIMULATION

CFD ANALYSIS

THERMOGRAPHY

Many materials experience changes in their thermomechanical properties during heating and cooling. Changes that affect the reliability of products. Thermomechanical simulation allows engineers to understand how the structure of a device behaves under both thermal and mechanical loading, enabling the prediction of structural reliability. We evaluate each design from a thermal point of view, whether that be of a full luminaire or of just electronic, optical or mechanical designs and parts. We can offer assured results thanks to necessary close partnership with all other engineering departments.

THERMAL SIMULATION MAKES SENSE

- SELECT THE MOST SUITABLE MATERIALS AND TECHNOLOGIES
- ENABLES OPTIMISATION OF A PRODUCT'S WEIGHT
- SUPPORTS THE BEST POSITION OF COMPONENTS WITHIN A PRODUCT
- POSITIVE INFLUENCE ON ENVIRONMENTAL FACTORS
- ALLOWS FOR OPTIMISATION OF HEATSINKS ACCORDING TO CONDITIONS TO MINIMISE COSTS
- UNDERPINS APPROPRIATE COMPONENT SELECTION

SOLUTION OPTIMISATION

Advanced computer simulations allow us to analyse and understand the performance of structures and systems so that we can improve them. This requires the cooperation of engineers and designers throughout product development with the aim of providing useful and constructive feedback and ideas. Thermal simulation is performed using SOLIDWORKS equipped with a wide range of additional modules.

LIFETIME PREDICTION

The basic steps involved in thermo-mechanical lifetime assessment are fluid dynamics studies, transient thermal calculations, and mechanical computations that identify loading conditions. Lifetime estimation for thermally and mechanically loaded products is both time-consuming and expensive. Therefore, fatigue simulation is a vital part of the development process as it minimises timescales and costs.



CFD ANALYSIS

THERMOMECHANICAL SIMULATION

CFD ANALYSIS

THERMOGRAPHY

Our thermal engineers are able to evaluate not only the influence of heat on a product, but also the influence of fluids (gases or liquids). In the case of luminaires, this can be with regard to the influence of wind or air conditioning. Such analysis helps to predict what force constitute a dangerous situation, and how the product will behave under these conditions.

WHY CFD ANALYSIS?

- TO DESIGN A PRODUCT FASTER AND MORE RELIABLY
- TO ASSESS PERFORMANCE AND EFFECTIVENESS BEFORE COMMITMENT TO TOOLING
- TO OPTIMISE LUMINAIRE PERFORMANCE
- TO EVALUATE PRODUCT WEIGHT AND HEATSINK TYPE
- TO HELP BALANCE OVERALL PERFORMANCE WITH DESIGN AND PRICE
- TO EVALUATE MANUFACTURING POSSIBILITIES
- MAIN APPLICATIONS INCLUDE OUTDOOR, INDUSTRIAL, TRAFFIC, SIGNAL, AND AUTOMOTIVE LUMINAIRES

FORCE PREDICTION

To minimise and control the risk of dangerous conditions from exceptional air velocities, forces, pressures, and accelerations, it is important to assess and understand the effects of such forces on all components and the assembly of a product. Strong winds such as those experienced during heavy storms and hurricanes induce forces and pressured distributions on objects that can lead to safety issues and potentially dangerous conditions. To avoid disaster, force predictions for a product need to be incorporated into its design from a very early stage.

FLUID DYNAMICS

The analysis of a fluid (gas or liquid) within a device is very complex as it is based on heat transfer, mixing, and unsteady and compressible flows. To predict the impact of fluid flow on a product can be both time consuming and very costly without appropriate simulation tools. Computational Fluid Dynamics (CFD) analysis enables the quick and efficient simulation of both fluid flow and heat transfer in order to calculate fluid forces and understand the impact of a gas or liquid on product performance. By performing robustness predictions for an untested idea, fluid dynamics helps us to place true design innovation within reach.

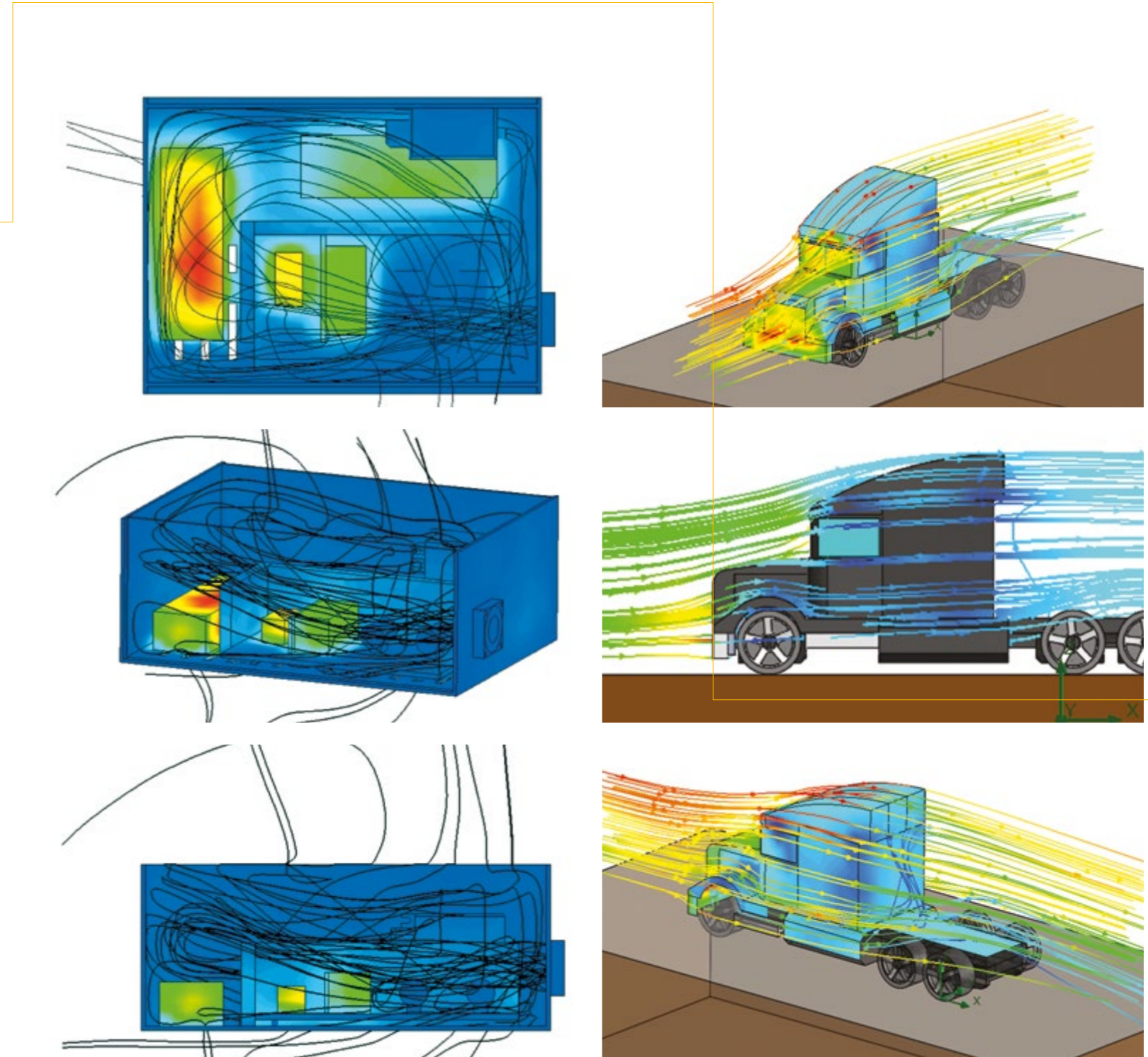

THERMOGRAPHY

THERMOMECHANICAL SIMULATION

CFD ANALYSIS

THERMOGRAPHY

Radiation is one of the heat transfer mechanisms in which electromagnetic radiation is emitted by a heated surface. Heat transferred by radiation does not depend on contact and can be transmitted through empty space. Examples of radiation are heat from the sun or the heat emitted by the filament of a light bulb. Advantages of using thermography include its ability to capture real-time temperature states, produce a picture of temperature over a large area, and measure inaccessible areas, as well as the fact that it is a non-destructive procedure.

WHEN WE USE THERMOGRAPHY

- TO IDENTIFY THERMAL DESIGN ISSUES BY CAPTURING REAL-TIME TEMPERATURE STATES
- FOR VIEWING OF TEMPERATURE PARAMETERS OVER A LARGE AREA
- FOR MEASUREMENTS OF INACCESSIBLE AREAS
- IN CASES WHERE CONTACTLESS MEASUREMENT IS REQUIRED

REAL-TIME CAPTURE OF INFRARED IMAGES

Thermography enables us to measure temperatures in applications where conventional sensors can't be used. This is especially the case when dealing with the measurement of moving objects or where contactless measurement is required due to the risk of contamination or hazardous occurrences.

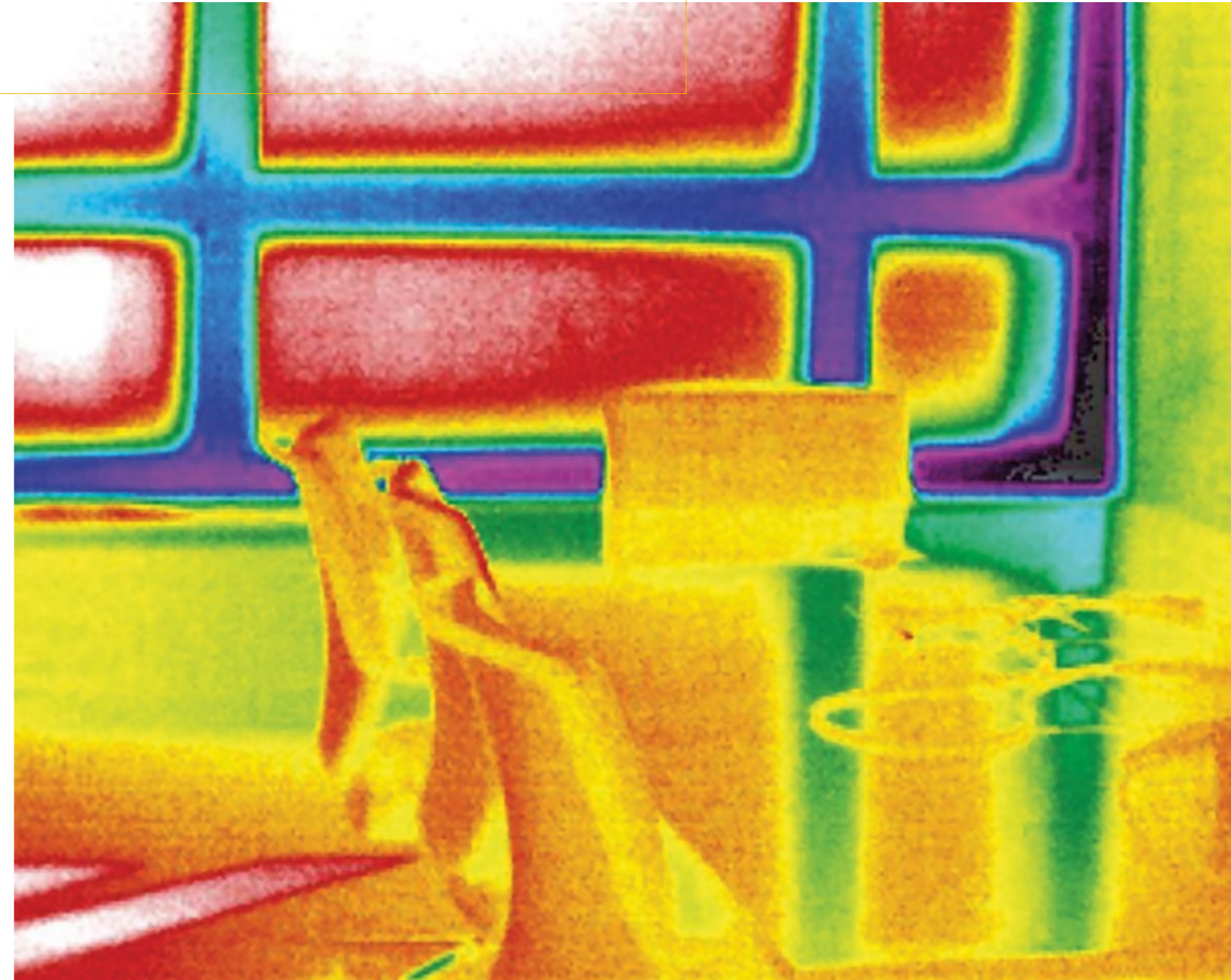
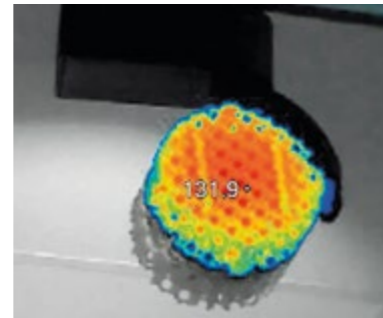
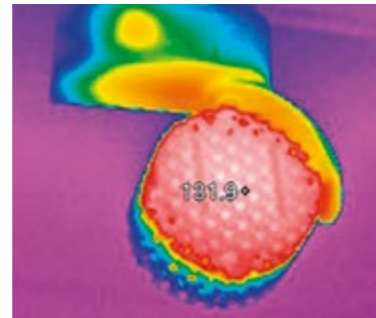

LED LUMINAIRE LIFETIME PREDICTION

It is sometimes very difficult to work out the truth about a luminaire's lifetime, so a simple explanation is in order. What exactly does LM80/TM21 mean in relation to a luminaire's lifetime? The short answer is... not a lot!

LM80 and TM21 refer only to the predicted lifetime of LEDs and COBs. How the LEDs are mounted, cooled, and driven are the key factors affecting luminaire lifetime. What LM80 and TM21 data does do, however, is provide luminaire manufacturers with a way to directly compare LEDs or COBs to allow them to make the best choice of component to achieve a good luminaire lifetime.

WHAT DOES IT MEAN IN SIMPLE TERMS?

IES LM80-80-2008 "Measuring Lumen Maintenance of LED Light Sources" is the industry standard method for testing LEDs to determine lumen depreciation over time. It is carried out over a 6000 to 10,000 hour period, with luminous flux measured at 1000 hour intervals. As a typical example, let's say the depreciation is 3%. That means a 97% maintenance of light output. And further, perhaps after 10,000, there is a depreciation of 6% or 94% maintenance.

Historically that was it, and LED manufacturers could draw their own curve through the test points and boldly quote a 50,000 hour lumen maintenance of 70% (L70) output while others would go as far as to quote 90% (L90). Basically, before TM21 came along, there was no agreed standard as to how to predict the end of useful life. This was not helpful for us as luminaire manufacturers, or you as customers.

IES TM21-2011 "Projecting Long Term Lumen Maintenance of LED Light Sources" recommends a method how to use the LM80 data to predict the lumen maintenance of an LED. Simply put, an exponential curve is drawn between the 1000 hour test points on a graph plotting lumen maintenance from 70% against a timeline of up to 100,000 hours. This could well give a calculated figure of L70 = 50,000 hours.

However, it is also stipulated in TM21 that the maximum life that may be quoted is six times the actual test duration. So, if the test duration is only 6000 hours, the maximum life that can be quoted is 36,000 hours and would be quoted as L70 (6K) >36,000 hours. If 10,000 hours of testing were carried out, it would be quoted as L70 (10K) >60,000 hours.

It's obviously more complicated than this and the tests are actually carried out at 3 different LED case temperatures; 55 °C, 85 °C, and a manufacturer selected temperature. (The meaningful one is 85°C as this represents practical conditions).

Don't forget, this is just telling us about the performance of an LED in lab conditions with controlled cooling and drive current, and doesn't take account of ambient temperatures or power supply. Beware, therefore, what is quoted as a luminaire lifetime. We've seen lifetimes of >100,000 hours L90 at 25 °C quoted in big letters on luminaire datasheets, and in small print, "this is with a junction temperature of $T_j = xx$ and is the LED manufacturers data". It looks good, but is rather misleading.

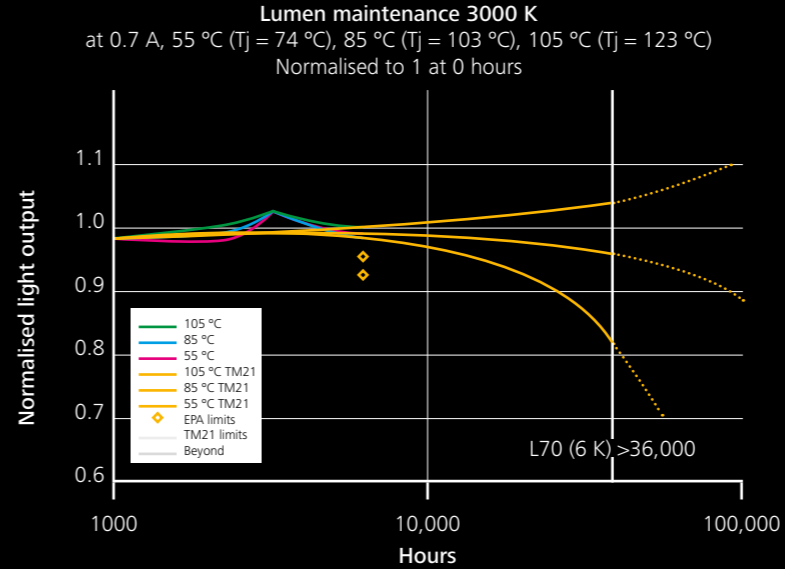

LM80 DEGRADATION CURVE OF AN LED LIGHT SOURCE

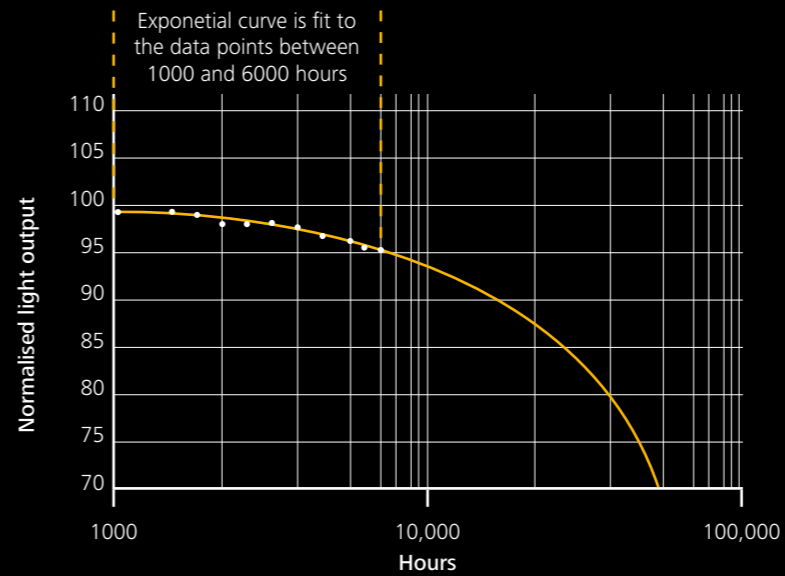

TM21 DEGRADATION CURVE OF AN LED LIGHT SOURCE

LM80 TEST

The LM80 test is a Department of Energy (DOE) approved method for measuring lumen depreciation of solid-state (LED) light sources, arrays, and modules. The Illumination Engineering Society (IES) and DOE Solid State Lighting Standards Development group worked together to create the LM80 test criteria.

TM21 TEST

In August 2011, IES published a TM21 document entitled "Lumen degradation estimation method for LED light sources." TM21 is the IES-recommended method for projecting the lumen degradation of an LED package, array, or module, based on data collected according to LM80.

The lighting community expects TM21 to become the standard method for projecting useful LED lighting product life at realistic operating temperatures.

ELECTRONIC DESIGN

Whether you need to develop new hardware, a PCB, or need support in software development, we will help you reach the finishing line. We have the expertise and experience to design hardware and software to meet your exact needs, and can take a project from concept through production under one roof.

“It’s hardware that makes a machine fast.
It’s software that makes a fast machine slow.”

Craig Bruce

HARDWARE DESIGN

HARDWARE DESIGN

FIRMWARE DESIGN

SOFTWARE DESIGN

LABWARE DESIGN

ELECTRONIC DESIGN
CONSULTANCY

Since hardware is the basis of each electronic device, there is vital need for good hardware design to ensure the quality, reliability, and long-term stability of a solution. Our hardware design engineers are responsible for the complete development process from idea to final product.

HARDWARE DESIGN INCLUDES

- KEY COMPONENT SELECTION WITH COST EVALUATION
- ELECTRONIC/PCB SCHEMATIC DESIGN
- FUNCTIONAL PROTOTYPING
- TEST REPORTS AND COMPLETE DOCUMENTATION
- POSSIBILITY TO CONTINUE WITH MANUFACTURE ON REQUEST
- USE OF THE DALI LOGO IF APPLICABLE

KEY COMPONENT SELECTION

The overall cost and complexity of a device depends mainly on key component selection. The ratio between those parts needed for the hardware, firmware, and software of the product are put in place during this phase of development.

SCHEMATIC DESIGN

The functional schematic of a solution is based on chosen key components, supporting blocks, and the analysis of customer needs. Schematic define the complexity and final cost of a developed solution.

PCB DESIGN

PCBs are designed based on a functional schematic with consideration also given to mechanical factors. The design is strongly influenced by forecasted production quantities, based upon which appropriate PCB manufacturing technologies are selected. Electrical safety requirements also have an impact on the design rule check.

PROTOTYPE

A prototype is an integral part of the development process as it is the first real substantiation of your vision. It also acts as the base for demonstration of functionality and subsequent corrections and price adjustment of the product. Several prototypes can be prepared during development.

DOCUMENTATION & VALIDATION

One of the primary outcomes of the development process is the technical documentation of the product. This enables customers to run serial production as well as being a requirement for product certification.

FINAL PRODUCT

Finalisation of the development process is marked by the product entering serial production. This is based on the aforementioned technical documentation and requires that the product first receive appropriate certification. We also offer you the possibility to continue with the manufacture of your device or product at an attractive price level.

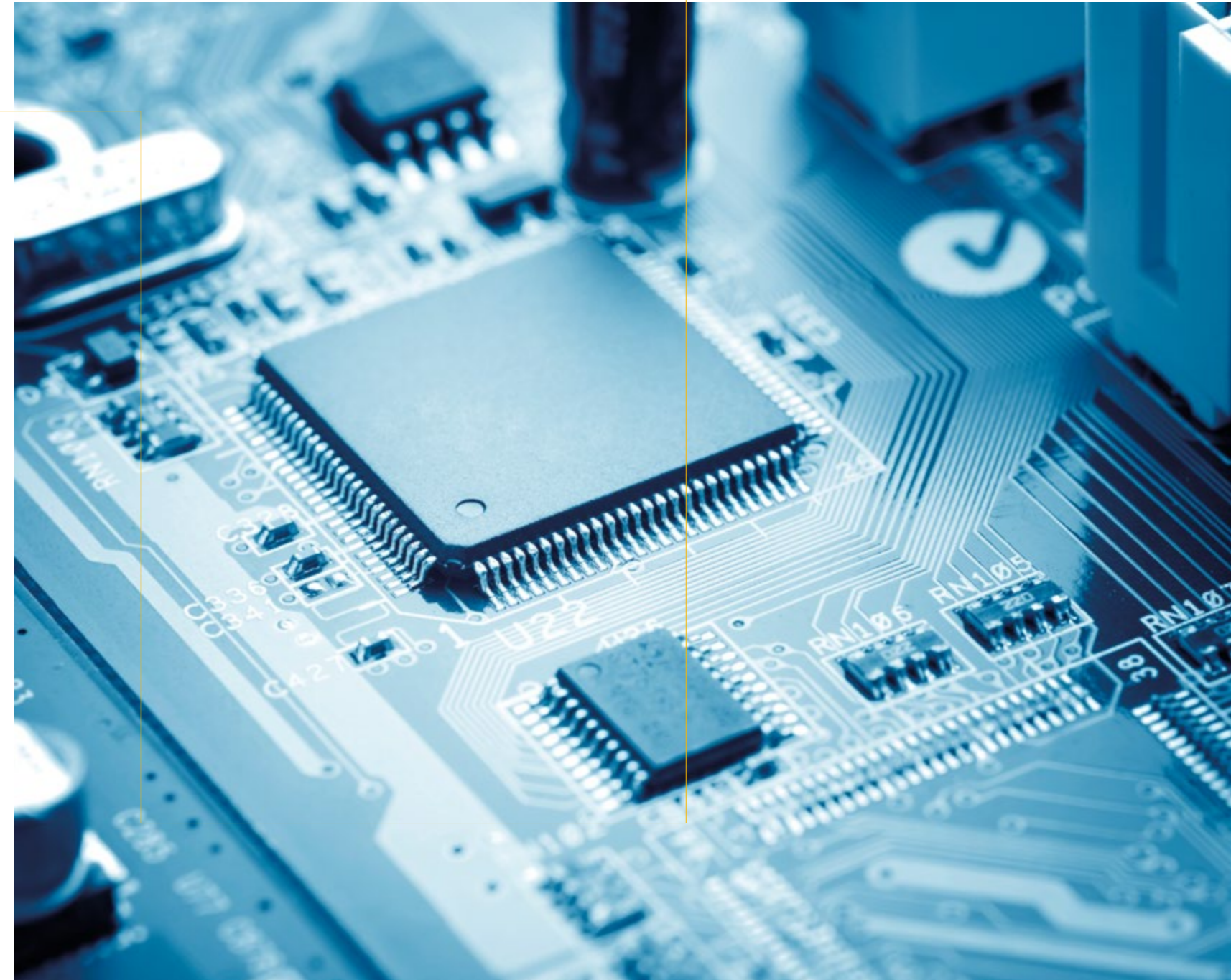

FIRMWARE DESIGN

HARDWARE DESIGN

FIRMWARE DESIGN

SOFTWARE DESIGN

LABWARE DESIGN

ELECTRONIC DESIGN
CONSULTANCY

Firmware, or programmable components, are used in almost every electronic product found on today's market. We have been dealing with firmware design for several years, mainly in the field of 8- and 32-bit core ST Microelectronics architecture. However, we can also work with manufacturers such as Microchip, Atmel, NXP, or any other. This experience, in combination with use of advanced software tools STVD, Eclipse, and Keil MDK, mean that we can provide high-level firmware design on request.

WHY FIRMWARE FROM US?

- WE HAVE AT OUR DISPOSAL A VAST LIBRARY OF READY-TO-USE SOLUTIONS
- WE PROVIDE COMPLIMENTARY HARDWARE AND SOFTWARE DESIGN
- WE HAVE DIRECT ACCESS TO THE LATEST TECHNOLOGIES
- WE PROVIDE FIRMWARE UPDATES

FIRMWARE SOLUTION ANALYSIS

Analysis of a firmware solution is fundamental to the final electronic design and results in the estimation of hardware requirements, MCU selection and a flow chart. We will need you to provide a list of features you expect the firmware to incorporate, based upon which we will decide if it is suitable to use an MCU. If so, we will provide an analysis of the solution including an estimated memory size and details of any peripheral units that may be needed as well as the size of the required MCU and its selection. The final step is to prepare the firmware flow chart.

COMPLETE FIRMWARE DESIGN FOR PROTOTYPE DEVICE

The next phase is to design the firmware itself. We select ready-to-use functional blocks or create completely new ones and then define the relationships between them. The outcome is functional firmware tested on a real prototype. Accompanying full documentation includes source code, any necessary software tools, and a comprehensive description of the design.

SUPPORT & MAINTENANCE OF FIRMWARE FOR MANUFACTURE

There is a world of difference between firmware designed for a prototype device and that needed for serial manufacture. For manufacture, it is necessary to take into consideration the workflow needed for the programming of devices. We can provide device programming within our own facilities or prepare for you a programming tool to use in your own facilities. It is common during the first months that some 'bugs' will appear, and you may also have ideas about how to improve the product. For this reason, we are also happy to correct and update firmware.

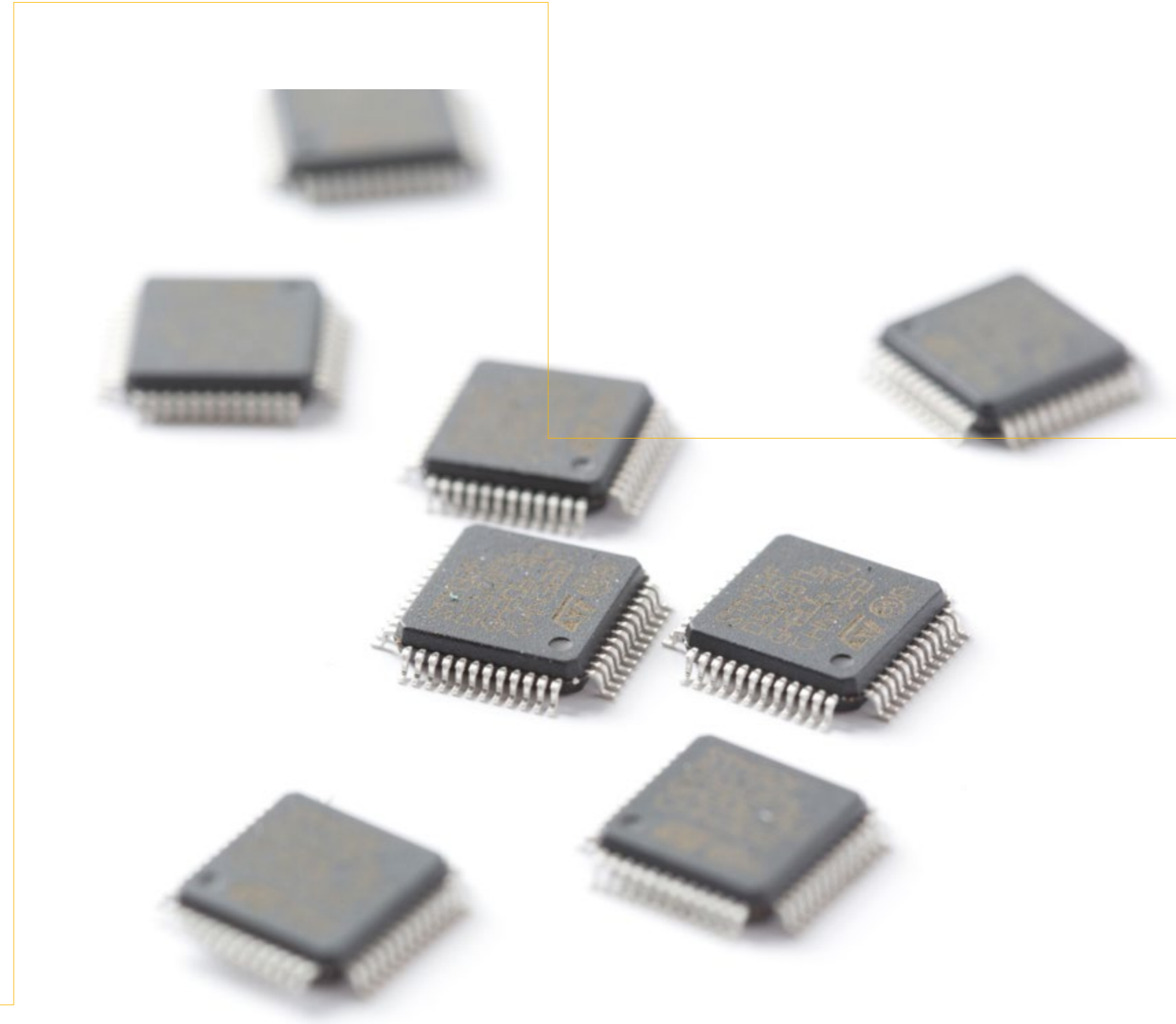

SOFTWARE DESIGN

HARDWARE DESIGN

FIRMWARE DESIGN

SOFTWARE DESIGN

LABWARE DESIGN

ELECTRONIC DESIGN
CONSULTANCY

There are hundreds of thousands of software programs on the market that can do almost anything you could desire, yet, these programs are so diversified and specified that it is nearly impossible to find one that does everything you need in one package. This necessitates the creation of something precisely tailored to your needs, which we can provide by combining our vast experience with use of the most appropriate development tools: LabVIEW, MS Visual Studio, and Android Studio.

SOFTWARE THAT BRINGS ADDED VALUE

- WE PROVIDE EXPERIENCE IN DELIVERY OF COMPLEX PROJECTS
- WE HAVE THE CAPABILITY TO DEVELOP TAILORED SOFTWARE WITHIN SHORT TIMESCALES
- OUR PROCESSES COMPLY WITH ISO 9001:2008
- WE OFFER FUTURE SOFTWARE UPDATES

SOFTWARE DEVELOPMENT

Our extensive and wide-ranging experience in the design of all types of software for any PC or portable device platform is one of the reasons why you can rely on us. All software is developed in close cooperation with hardware and firmware to provide results characterised by their usability, portability, maintainability, reliability, and security. Using smart programming approaches, we are able to develop qualitative software solutions within very short timeframes. We apply proven design patterns to ensure best practice and rapid development, and can provide updates thanks to use of Unified Modelling Language (UML) to combine techniques from data, object, and component modelling, which makes it easier and faster to implement future modifications thanks to refactoring.

CUSTOMISED SOLUTION

Software brings added value to a product when it precisely meets customer needs, and can, if appropriate, be controlled and set-up remotely. We can also update, optimise, or customise existing software with open protocols according to your needs, such as the software used in our own Connected Lighting range of products.

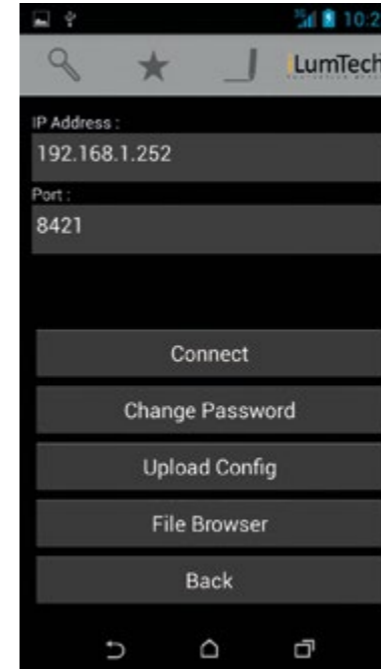

LABWARE DESIGN

HARDWARE DESIGN

FIRMWARE DESIGN

SOFTWARE DESIGN

LABWARE DESIGN

ELECTRONIC DESIGN
CONSULTANCY

Labware is a specific kind of software that automates operations in laboratories or in industry applications, controls machines and measuring instruments, and acquires data and process it. Our solutions are based on the LabVIEW development environment, which enables short development cycles, user-friendly GUI design, and a large number of libraries for data acquisition, data processing, data generation, mathematical analysis, statistics creation, etc. The extent of the features available allows us to offer complete turnkey solutions for fully-automated customer-defined measurement and processing units.

LABWARE DESIGN INCLUDES

- DATA ACQUISITION SYSTEM DESIGN
- DESIGN OF AUTOMATIC MEASURING SYSTEMS
- DEVELOPMENT OF INSTRUMENT CONTROLS AND DEVICE DRIVERS
- DATA PROCESSING, MATHEMATICAL ANALYSIS AND STORAGE TOOLS
- MACHINE CONTROL AND VISION DESIGN
- COMPLETE TAILORED SOLUTIONS

DATA ACQUISITION SYSTEMS

Data acquisition systems are responsible for measuring and sampling electrical or physical quantities and their subsequent processing. A complete data acquisition system is composed of sensors, measurement hardware, and a computer with programmable software. Such solutions are powerful, flexible, and cost-effective.

AUTOMATIC MEASURING SYSTEMS

Automatic measuring systems are useful when large numbers of electrical or physical quantities need to be measured, necessitating the use of many different data acquisition devices. It is possible to synchronise the functions of all devices using a programming environment. The basic steps involved in this synchronisation are the setting of hardware parameters, acquisition of data, evaluation of that data, and the creation of reports.

INSTRUMENT CONTROL & DEVICE DRIVER DEVELOPMENT

Device drivers act as the software interface with the hardware device and should contain all the implemented functions. The main purpose of the driver is to create a higher-level application without requiring users to have detailed knowledge of the device hardware.

DATA PROCESSING, MATHEMATICAL ANALYSIS & STORAGE

Data acquisition is the term used for the process of manipulating data in various ways in order to obtain meaningful results. These manipulations include mathematical calculations, signal processing, and report generation.

MACHINE CONTROL & VISION

Machine vision is a technology used for automated inspection of and within industrial processes to achieve higher product quality. Other uses include the control of production processes and industrial robots. Machine control and vision ensures high industrial process throughput and reduced production costs. A complete turnkey solution for a customer-defined measurement and process unit can be realised in one project. Each project includes hardware, firmware programming of the designed hardware, development of a device driver to act as the interface between the hardware and a higher-level application, and development of the control application.



ELECTRONIC DESIGN CONSULTANCY

HARDWARE DESIGN

FIRMWARE DESIGN

SOFTWARE DESIGN

LABWARE DESIGN

ELECTRONIC DESIGN CONSULTANCY

The performance of an electrical device is influenced by many factors. There are some basic principles that you can learn, but the real master of electronic design firstly needs to be experience. We can help you build high-performance and reliable systems and create custom designs using our experience and knowledge. Support includes the provision of reference designs, detailed device and system design rules, design reviews, and general advice.

HAVE A PROBLEM YOU NEED HELP WITH?

- WE CAN IDENTIFY YOUR PROBLEMS
- WE PREPARE EVALUATIONS OF PROPOSALS WITHIN SHORT TIMESCALES
- WE PROVIDE CONSULTANCY AND ADVICE
- WE OFFER TRAINING
- WE CAN ORGANISE FUNCTIONALITY TESTS

ELECTRONIC DESIGN REVIEW

Inspection of electronic designs during the development process can uncover potential weak points and risk areas, which should be treated carefully by a responsible and experienced developer. During the electronic design review, we offer our extensive knowledge and expertise to help designers avoid problematic or clumsy solutions and so shorten the development process. Based on the advice we offer during consultation, electronic development can proceed in an optimal way thanks to the use of already proven and tested design blocks.

PROJECT SUPPORT

Our skilled electronic engineers can also support you in the selection of devices suitable for your project, including any from our own Connected Lighting portfolio. According to information about the project, such as usage, application, budget, and luminaire type, we can recommend the best type of Lighting Management System (LMS) as well as offer LMS consultancy.

LIGHTING MANAGEMENT SYSTEM CONSULTANCY

Good lighting does not stop at selection or development of the right luminaires, it also includes their intelligent regulation. For this, you will need a suitable LMS. And what constitutes a suitable LMS? Only that which understands and reacts to the real needs of users, offers the functions actually needed and does not waste money with those that are not, and which is easy to use. Our experience of LMS devices and design, along with use of our own Connected Lighting portfolio, allows us to make your life easier with tailored LMS designs.



THE TUNABLE WHITE STORY

It is several years since the lighting industry began to consider dimming and the use of DALI as standard. Now, the same process is taking place regarding Tunable White as customers accept and even expect use of the technology in solutions. Despite this broad acceptance, the functional principles of Tunable White are still not widely understood: what are the differences between Tunable White technologies, how are the devices controlled, what possibilities are available, and how can a desired CCT be maintained.

MAKE THE RIGHT CHOICE

Standard Tunable White technologies rely on the use of two independent power sources, one each for the warm and cold LED modules of the luminaire, necessitating the use of complex dimming and CCT control and additional regulation to avoid over-illumination caused by full powering of both modules. This results in the inclusion of more components, leading to lower product and operational reliability. Furthermore, the efficiency of the luminaires is affected by the CCT set, with optimal efficiency only achieved at the warmest and coolest CCTs.

iLumTech's Tunable White is different – truly tunable. Brought to the market in the Connected Lighting family, it is based on a totally different principle, somewhat like that of a two-way valve. An electronic switch is used to regulate the direction of a single current flow to both warm and cold LED modules, meaning that only one power supply is needed and over-illumination impossible. This leads to higher reliability thanks to simpler dimming and CCT control. What's more, the luminaire's efficiency is stable across all CCTs. iLumTech Tunable White modules come with a range of regulation methods including manual push button control, DALI control, and advanced user-interface control.

The Connected Lighting family contains two different types of Tunable White module: DALI type 6 and type 8. DALI type 6 modules require the use of two DALI addresses, one for brightness control and one for CCT control. DALI TW type 8 modules have the same functionality but do not require the use of an additional address as brightness and CCT can be regulated together using special commands.

The story of Tunable White does not end with LED modules and luminaires. Users also need to control them and take full advantage of their functionality through DALI. We consider it important that customers fully understand the differences between standard and advanced control, and so can identify the most suitable for each application.



A NEW PERSPECTIVE ON TUNABLE WHITE

It is well known that the function of Tunable White luminaires is to provide illumination with various CCTs as required. The ability of Tunable White in combination with dimming to facilitate human centric lighting is especially beneficial in areas where people need to maintain concentration for extended periods of time or to relax and perform according to a preset schedule. Such areas include offices, classrooms, kindergartens, and hospitals. However, optimal illuminance and CCT parameters can easily be unbalanced by light coming from other sources, for example that from other luminaires or daylight from outside. Is there a way to maintain desired illuminance and CCT values despite outside influences?

Luckily, we have developed the solution. The iLumTech DALI Ambient Sensor is the first of its kind on the market – able to measure both the illuminance (lux) and CCT (Kelvins) of ambient lighting parameters according to a spectrum weighted by tri-stimulus values X, Y and Z. The sensor can be used to adjust illuminance and CCT values at a task area to maintain desired values in either a passive capacity by informing another control device on the same DALI bus, or in an active capacity as a combined sensor and control unit.

The DALI Ambient Sensor is capable of controlling various types of Tunable White luminaire: standard ones with independent cold and warm regulation and requiring two DALI addresses, DALI type 6 ones with independent CCT and illuminance regulation and requiring two DALI addresses, and DALI TW type 8 ones with combined CCT and illuminance regulation and requiring a single DALI address. Regulation is facilitated through grouping of luminaires according to their type, up to a maximum of five groups. This allows for luminaires of all types to be controlled simultaneously using group addresses for cold, warm, illuminance, CCT and DALI TW type 8 channels. Once the sensor is properly configured for active operation, it can function as a stand-alone master controller on a DALI bus without the need for any other control unit. It is, however, possible to add extra control devices if desired.

The DALI Ambient Sensor is suitable for ceiling installation and should be connected to a DALI bus. Desired illuminance and CCT values can be defined using the iLumTech DALI to USB Bridge. The used protocol is currently of a proprietary nature but will be mapped to the updated DALI standard upon its completion, expected in 2016/17.

MECHANICAL ENGINEERING

The experience and skill of our engineers combined with the power and flexibility of the latest 3D CAD software from CATIA allows us to design and customise whole products or their individual parts. Our precise document management system assures that you will receive all proper documentation from which you can work in future. All data is available in 2D and 3D in various file formats: STP, IGES, DXF and DWG.

“An optimist will tell you the glass is half-full; the pessimist, half-empty; and the engineer will tell you the glass is twice the size it needs to be.”

Anonymous

SHEET METAL DESIGN

SHEET METAL DESIGN

ALUMINIUM DIE CAST
& EXTRUSION DESIGN

ALUMINIUM FORGING

MECHANICAL ANALYSIS

Sheet metal is a very common material used in the construction of many products, from cars to aeroplanes. We know all there is to know about shaping, forming, and combining sheet metal with other materials.

WHAT YOU WILL RECEIVE

- ITEM AND COMPILATION DRAWINGS
- SETTLEMENT SHEET DRAWINGS
- 3D CATIA STP FILES
- BEND RADIUS CALCULATIONS
- MECHANICAL BILL OF MATERIALS
- PRODUCTION TECHNOLOGY EVALUATION AND PROPOSAL

SHEET METAL DESIGN

Sheet metal design is not dependent on or limited by the forming process chosen, which is selected according to application and cost evaluations. However, it is important to bear in mind that each forming technology requires different tolerances and material properties. You can rely on us to take care of the details.

PRODUCTION PROCESS SELECTION

Depending on production quantities, product quality, and usage, we select the final sheet metal production process. This could be anything from bending and stamping to hydroforming, among many others.

ITEM DRAWINGS

The whole is always the sum of its parts, therefore, we will supply you with detailed drawings of every single part, including the parameters of their production.

COMPILATION DRAWINGS

To make a full technical drawing, the content of all items drawings are compiled and adjusted to the final versions.

BILL OF MATERIALS

BOM, short for 'Bill of Materials', is the summary of all parts used in a product. BOMs are provided according to international standards, but we can also adjust them to meet your specific needs and rules.

SHEET STRESS ANALYSIS

This allows us to design structures that can withstand specified loads using a minimum amount of material, or to meet some other optimisation criteria.

BEND RADIUS CALCULATIONS

Bend radius calculations enable us to evaluate final design, material usage, and production technology possibilities. This evaluation may lead to shape modification or the use of a different material that is able to withstand a required bend radius.

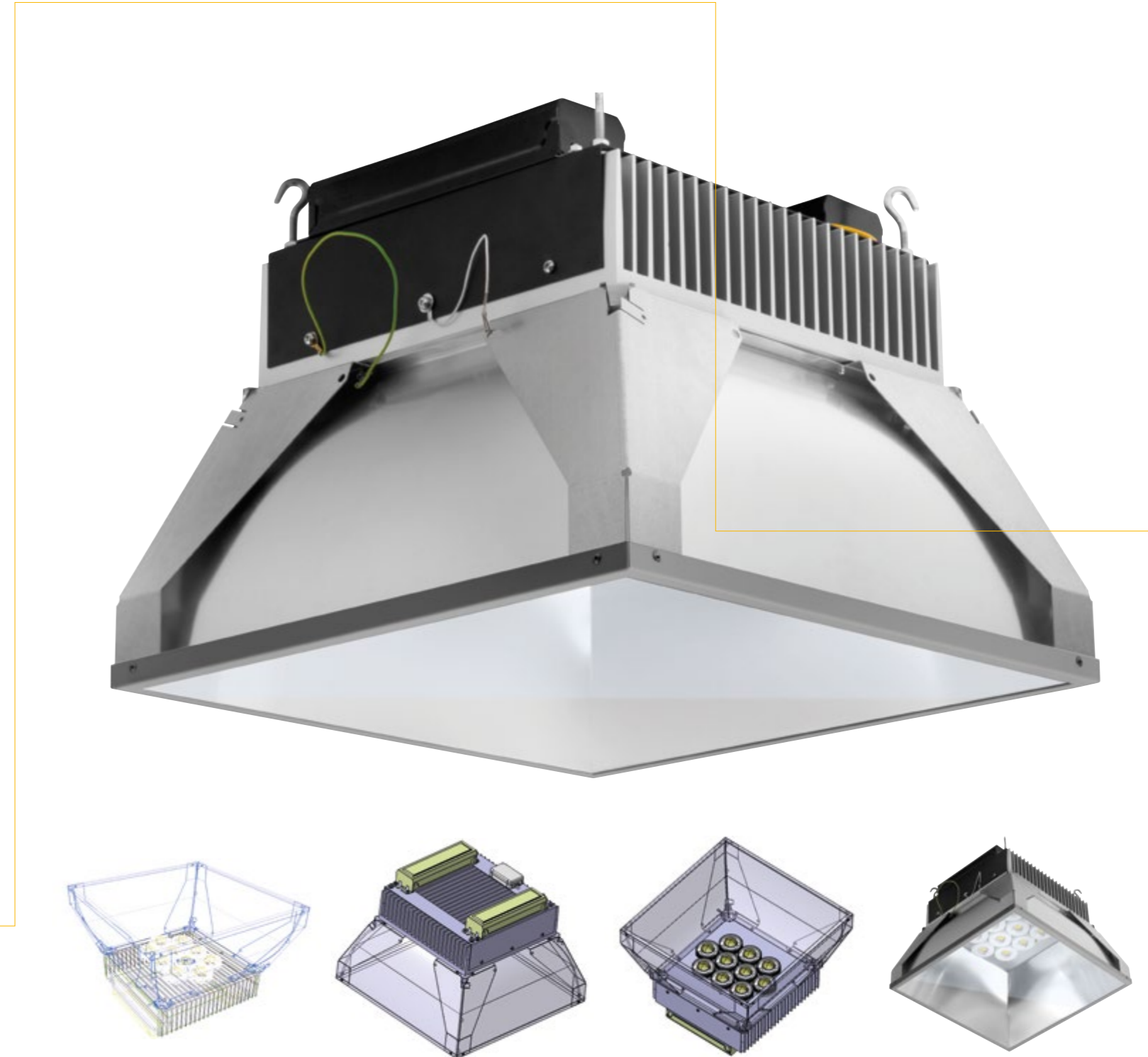

ALUMINIUM DIE CAST & EXTRUSION DESIGN

SHEET METAL DESIGN

ALUMINIUM DIE CAST & EXTRUSION DESIGN

ALUMINIUM FORGING

MECHANICAL ANALYSIS

The processes of die casting and extruding aluminum have been available for approximately 90 years. Beneficial, not only in terms of their ability to influence the feel of a product, these processes have been developed to allow for high-speed production for many industries in order to meet demand.

TAILORED TOOLING

- ALLOWS YOU TO HAVE THE EXACT SHAPE YOU NEED
- CAREFULLY SELECTED TOOL TYPE AND MANUFACTURER
- QUALITY CONTROL OF THE WHOLE PROCESS AND FINAL PRODUCT
- YOU OWN THE TOOLS AND ALL DOCUMENTATION

MECHANICAL DESIGN OF DIE CASTING PARTS

Die casting is a metal casting process characterised by the forcing of molten metal into a mould cavity under high pressure. Mould cavities function similarly to injection moulds, and are created using two hardened tool steel dies that have been machined into the desired shape. Most die castings are made from non-ferrous metals, specifically zinc, copper, aluminium, magnesium, lead, pewter, and tin-based alloys. Depending on the metal to be cast, a hot or cold-chamber machine is used. Within the framework of this mechanical design process, we provide tooling 3D model reviews and tool production support.

STRESS ANALYSIS

As with sheet stress analysis, this process assesses the effects of various forces and loads on materials and structures to aid in the design of satisfactory items.

MECHANICAL DESIGN OF EXTRUDED PARTS

Extrusion is a process used to create objects of a fixed cross-sectional profile by pushing or drawing a material through an appropriately sized die. The two main advantages of this process over other manufacturing processes are its ability to create very complex cross-sections, and to work materials that are brittle, because the material only encounters compressive and shear stresses. It also forms finished parts with an excellent surface finish. Extrusion may be continuous or semi-continuous and is a suitable process for hot and cold materials including metals, polymers, ceramics, concrete, play dough, and foodstuffs.

TOOLING PRODUCTION

Our strategic supply management regularly evaluates possible manufacturers from the precision automotive parts industry, and can select the one(s) most suitable for a particular type of tool or function. Selection is also done on the basis of experience as well as ISO certification and our own audit. During creation of the tools, we will keep you informed about the status of manufacture and the results of our regular tool audits. Our continuous overview of the tooling process ensures immediate reaction to and resolution of any issues to guarantee a perfect final output.



ALUMINIUM FORGING

SHEET METAL DESIGN

ALUMINIUM DIE CAST
& EXTRUSION DESIGN

ALUMINIUM FORGING

MECHANICAL ANALYSIS

Forging requires the use of materials that are able to withstand extreme processes such as heat, pressure and mechanical stress, but the results are suitable for mass production and deliver some outstanding material properties. For example, the thermal conductivity of a forged heatsink is double that of an extruded one, resulting in a much smaller and lighter weight product.

WHEN IS FORGING THE PROCESS OF CHOICE?

- IF YOU NEED A PRODUCT ABLE TO WITHSTAND HIGH TEMPERATURES
- WHEN YOU REQUIRE PARTS WITH HIGH CONDUCTIVITY
- IF YOU WISH TO INCREASE LUMINAIRE PERFORMANCE

MECHANICAL DESIGN OF FORGED PARTS

Forging is a manufacturing process that shapes metals using localised compressive force. To achieve the desired surface finish, it is necessary to further process the produced parts. Mechanical engineers must not only produce a suitable part design, but also select the best production method according to the requirements placed on the final product. There are various forging technologies available, and thanks to our experience in the use of this metalworking process, we can advise you which best meets your needs.

STRESS ANALYSIS

Stress analysis is required for forged products as for those made by any other process. By testing the effects of stress on the forged items, it is possible to optimise the design to meet specified needs.

3D MODELING (STP, IGES)

3D modelling of the parts help us to visualise the final product, and acts as the base for creation of 3D printed or milled prototypes before tooling. You will receive such files for your own evaluation.

TOOLING SELECTION

Various needs necessitate the use of various tools. For long-run production, the tools must have a longer lifetime than those used for short-runs. We can advise you about the best tools to use depending on the predicted production quantity.

TOOLING 3D MODEL REVIEW

Forging results depend on the tools used, so is vital that they be precise and high quality. Before the production of your tools, we ensure their quality by checking the design and providing you with all necessary documentation.

TOOL PRODUCTION

We will choose the most appropriate tool manufacturer and take care of the entire tooling process including resolution of possible issues and evaluation of the tool's suitability compared to specifications. Only then is the final tool design confirmed, after which it will be delivered to the manufacturing location. You will be the certified owner of the tool.



MECHANICAL ANALYSIS

SHEET METAL DESIGN

ALUMINIUM DIE CAST
& EXTRUSION DESIGN

ALUMINIUM FORGING

MECHANICAL ANALYSIS

Does it work or not? A question you will hear repeatedly before a mechanical design is finalised. Nobody wants to invest time and money into the development of production tools and processes for a product that will need redesigning.

WHAT IS THE POINT OF MECHANICAL ANALYSIS?

- IT REDUCES OVERALL PRODUCT DEVELOPMENT TIMES AND COSTS
- IT MINIMISES QUALITY ISSUES AND SUBSEQUENT COMPLAINTS
- IT ENSURES PRODUCT RELIABILITY

STRESS ANALYSIS

Stress analysis will inform us about estimated stress and related failure sites. Mechanical engineers are responsible for the performance of analysis such as vibration-shock analysis, and in part also for thermomechanical analysis. Based on these analyses, we can predict functional degradation as well as estimate time margins for relevant failure mechanisms due to stress at failure sites.

STRUCTURAL ANALYSIS

This is an important part of mechanical design because it allows us to evaluate the force or load that a material can bear. During analysis, we assess structural deformations, internal stresses and forces, accelerations, and stability.

MOULD FLOW ANALYSIS

In an ever more competitive market, no company can afford flawed production and output, which wastes both time and money. For moulded parts, it is a vital to evaluate the quality of the moulds used, to ensure that all produced items are of the highest quality.

STATIC CALCULATIONS

Static analysis allows us to check the stability of a product in situ, taking into account installation and ambient conditions. This type of analysis simulates, for example, the stability of a suspended luminaire or the installation requirements of a street or wall luminaire, and has proven to be a fast, simple, and effective way to identify structural defects. There really is no excuse for developing a product without it.



RAPID PROTOTYPING

RAPID PROTOTYPING

FUNCTIONAL PROTOTYPING

3D PRINTING & CNC MILLING

ELECTRONIC PROTOTYPING

RAPID PROTOTYPING

A prototype allows you to explore your ideas and to show the intention behind a feature or the overall concept to users before investing time and money in development. It is much cheaper to change a product early in the development process than to make changes afterwards. Our ability to provide functional prototypes at such an early stage of development guarantees high flexibility and minimal investment as every mechanism and property of the product is checked before tooling.

“I love taking an idea... to a prototype and then to a product that millions of people use.”

Susan Wojcicki

FUNCTIONAL PROTOTYPING

FUNCTIONAL PROTOTYPING

3D PRINTING & CNC MILLING

ELECTRONIC PROTOTYPING

In close cooperation with all departments, our workshop engineers and industrial designers can create full prototypes using selected materials, components, and surface finishes to enable final product assessment and testing before certification and entrance into mass production.

ALMOST THE REAL THING

- 3D PRINTED PARTS
- CNC MILLED PARTS
- REAL FUNCTIONALITY
- INCLUSION OF REAL COMPONENTS

HIGH-FIDELITY MOCK-UPS

We have various technological possibilities at our fingertips, including 3D printing and CNC milling, that allow us to make cost- and time-effective high-fidelity models with complex structures and interior cavities. To these mock-ups, it is possible to add components, full functionality and even a realistic surface finish, lifting it almost to the level of a full prototype. Such mock-ups can be used in lieu of prototypes for final functionality and design assessment and presentation to investors.

FULL PROTOTYPES

Full prototypes are identical to the final product in every way, but made using different production methods. Usually, such products are produced by CNC milling of aluminium, which achieves the same result as a mass production method such as extrusion or forging, but on a smaller scale, and faster. It is often the case that several full prototypes are made prior to a product entering mass production for various uses, such as testing and certification, or for presentation to sales personnel and key customers.

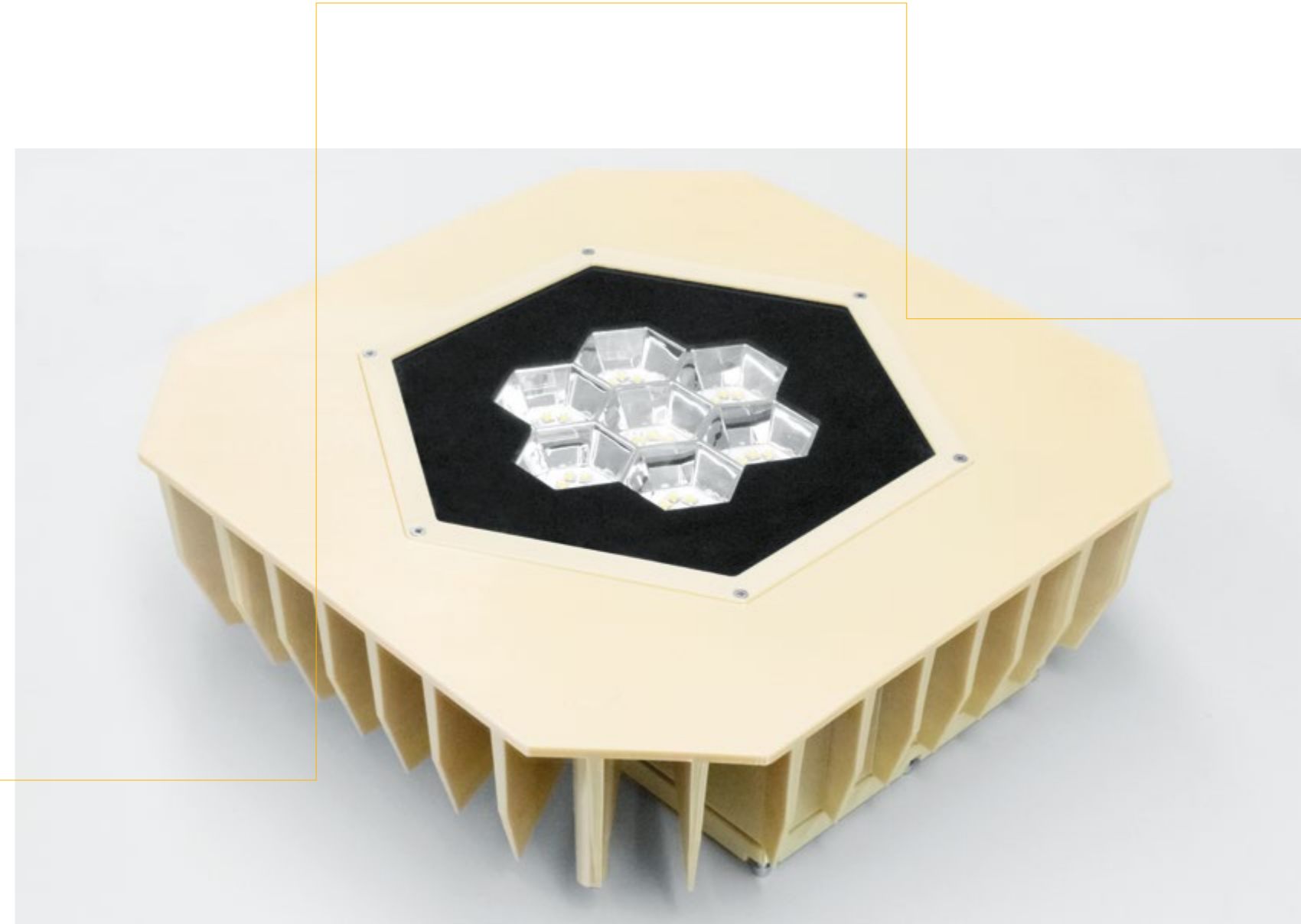

3D PRINTING & CNC MILLING

FUNCTIONAL PROTOTYPING

3D PRINTING & CNC MILLING

ELECTRONIC PROTOTYPING

How does it work? All you need to do is send us an STP file and we will prepare an offer and time schedule for 3D printing or CNC milling anything you want. Once we agree on commercial conditions, you can expect to receive your new model within just a few days.

3D PRINTING SERVICE

- 3D STP INPUT FILE
- 12-72 HOUR TURNAROUND
- ENVELOPE UPGRADE TO 406 x 355 x 406 MM
- MADE FROM ABS 30M

CNC MILLING SERVICE

- 3D STP INPUT FILE
- MATERIAL SUGGESTED DEPENDS ON PROTOTYPE PROPOSAL

3D PRINTING ON DEMAND

Use of our 3D printing services is a good way to release just a little of that pent-up creativity without blowing the budget on your own printer. We offer affordable 3D printing services to support you whether you are an industrial designer, are developing a new product, or just want to visualise your drawings and ideas. We can print objects (envelope upgrade to 406 x 355 x 406 mm) from ABS 30M within a very short time-scale, and for an attractive price.

CNC MILLING ON DEMAND

Milling is a cost-effective process for the production of aluminium parts. As complex shapes and high dimensional tolerances are possible, excellent surfaces finishes are provided, and the manufacture itself takes very little time, CNC milling is one of the most practical ways to produce a prototype. We can produce almost any 2D or 3D shape and offer CNC milling for the production of short-runs of new luminaires before final tooling. As these luminaires are made of aluminium, they are suitable to go through testing and performance verification. Final products are no different to CNC milled ones, therefore companies often take advantage of the process to produce prototype luminaires for exhibition and presentation before the final product is manufactured.

3D PRINTING & CNC MILLING AS A PART OF DEVELOPMENT

The use of 3D printed or CNC milled prototypes during product development speeds up the whole process, helping new technologies see the light of day sooner. Additionally, design validation prior to investment in large-scale production is crucial to profitable product development. Functional prototypes made of 3D printed or CNC milled bodies with real components provide the possibility to perform photometric tests, verify IP ratings, and evaluate the mechanical performance of the product. Such a prototype can be presented with confidence to your sales team and key customers in time for their modification suggestions to still be implemented.

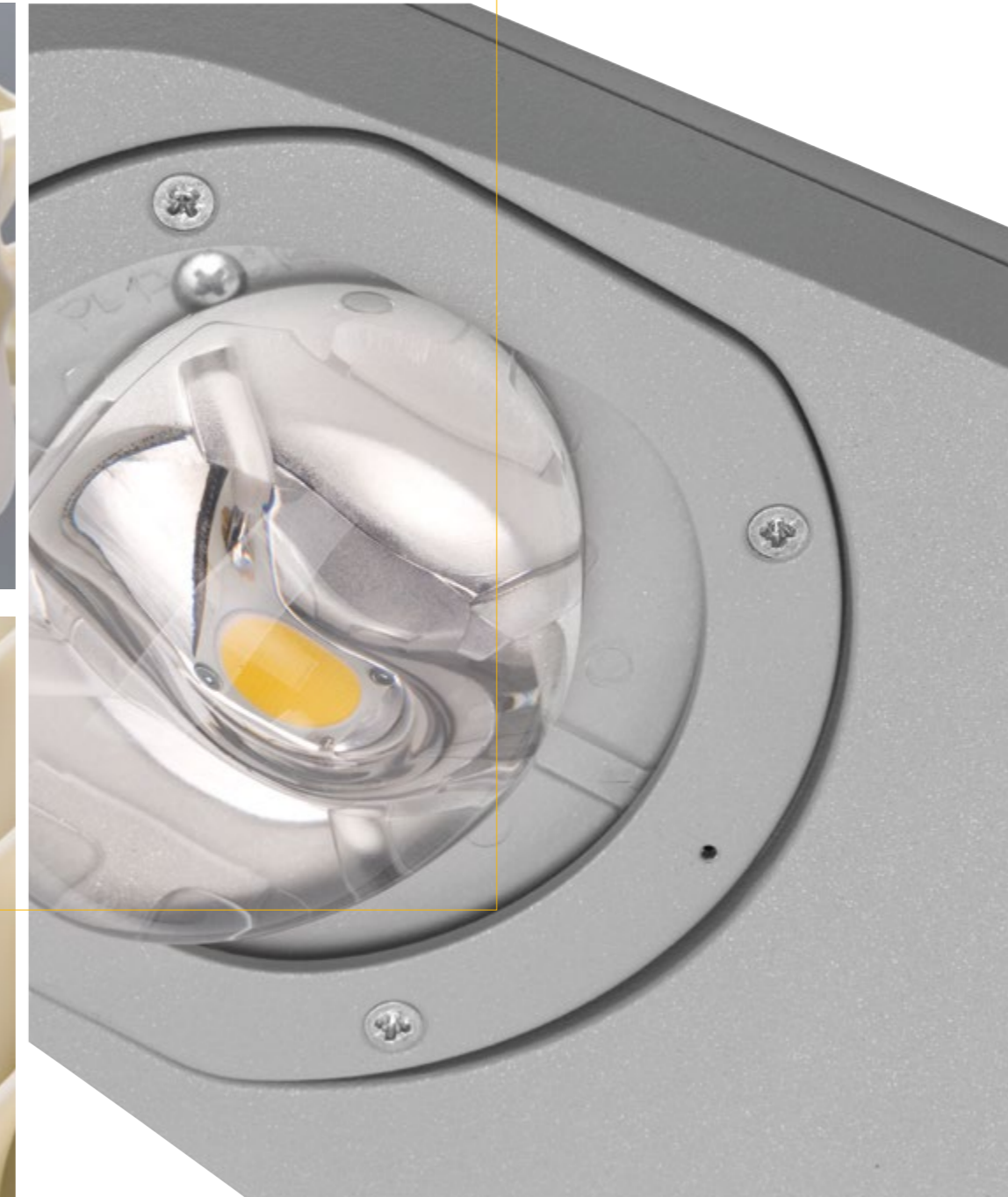
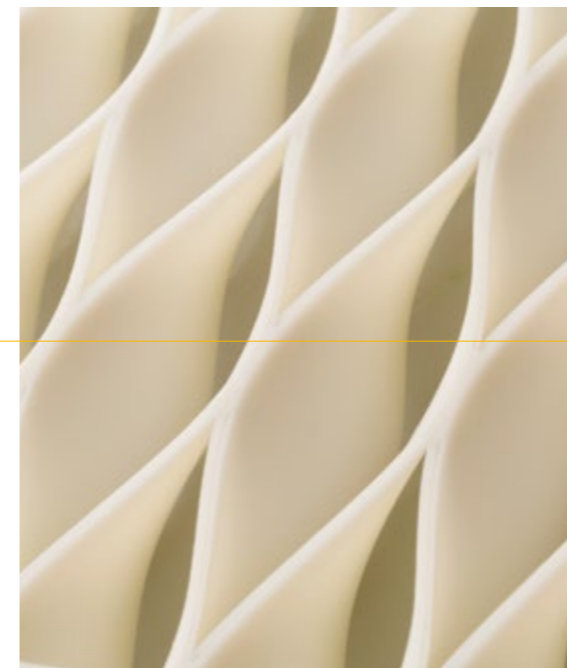

ELECTRONIC PROTOTYPING

FUNCTIONAL PROTOTYPING

3D PRINTING & CNC MILLING

ELECTRONIC PROTOTYPING

A comprehensively produced rapid prototype of any electronic device provides you with a strong competitive advantage. We manufacture, assemble, and test prototype PCBs and 3D printed or machined mechanical parts such as enclosures, all within very short timescales in our ESD protected, well-equipped laboratory.

RAPID PROTOTYPING PROCESS

- MICRO-MACHINING OF BARE PCB
- ULTRASONIC CLEANING
- SOLDER PASTE DISPENSING
- COMPONENTS PLACING
- INFRARED SOLDERING
- 3D PRINTING
- ASSEMBLY OF FINAL PCB

BARE PCB PROTOTYPING

Do you need just a few PCBs to make a prototype? Or do you need to create a customised solution? We can manufacture prototype PCBs using a TECHNODRILL 2 CNC drilling and milling machine or conventional chemical processing. PCB prototypes are produced according to supplied Gerber files.

PCB ASSEMBLY

We assemble both surface-mount devices (SMD) and through-hole devices. Reflow is carried out in a computer controlled infrared reflow oven. If you already have a PCB and simply require assembly, we will request that you send us the ready PCB and associated assembly sheet.

FUNCTIONAL PROTOTYPES

Functional prototypes are required for performance of a wide array of laboratory tests. If desired, functional and tested prototypes can be provided in standardised or customised boxes. If a customised box is required, we will also manufacture this prototype from aluminium or 3D printed plastic. If development of an electronic design (hardware) is also ordered, the requested number of completed prototypes will be sent to you for testing and evaluation in addition to all tests being performed in our own laboratories according to standards.



PRE-CERTIFICATION TESTS & MEASUREMENTS

PRE-CERTIFICATION TESTS & MEASUREMENTS

OPTICAL TESTS & MEASUREMENTS

THERMAL TESTS & MEASUREMENTS

ELECTRICAL & ELECTRONIC TESTS & MEASUREMENTS

MECHANICAL TESTS & MEASUREMENTS

THE LONG-TERM TEST LAB

DALI APPROVAL

PRE-CERTIFICATION TESTS & MEASUREMENTS

We offer one of the most comprehensive set of lab services available in the lighting industry – from optic through thermal and electronic to mechanical measurements. Our laboratory services are designed to increase the speed and precision of product development and certification. A full price list is available on request, or in the case of special demand, we will prepare an individual price offer for you.

“Every line is the perfect length if you don’t measure it.”

Marty Rubin

OPTICAL TESTS & MEASUREMENTS

OPTICAL TESTS & MEASUREMENTS

THERMAL TESTS & MEASUREMENTS

ELECTRICAL & ELECTRONIC TESTS & MEASUREMENTS

MECHANICAL TESTS & MEASUREMENTS

The wide scope of our testing technologies means we can offer a comprehensive range of tests and measurements. We use these technologies during product development, as well as to test existing ones, and to provide customers with product pre-certification verification and evaluation. Feel free to contact us if you require optical testing and measurements services for any luminaire or part.

AVAILABLE TESTS AND MEASUREMENTS

- LUMINOUS INTENSITY DISTRIBUTION CURVES
- RAY DATA (E.G. ASAP, SPEOS, LUCIDSHAPE, LIGHTTOOLS, ZEMAX, SIMULUX)
- PROCESSING AND ARCHIVING OF LVK DATA IN A PHOTOMETRIC DATABASE (LUMCAT)
- LUMINANCE OF CRTS, LED, AND ELs
- ROAD AND TUNNEL BRIGHTNESS
- RAIL-SYSTEM, ROAD AND AIRPORT SIGNALS
- ILLUMINATION EQUIPMENT AND DEVICES, AND OUTDOOR SIGNS
- RESEARCH AND MEASUREMENT TESTING
- DEVICE BRIGHTNESS AND BRIGHTNESS UNIFORMITY
- RGB COLOUR VALUES OF THE CMOS MATRIX
- LUMINOUS FLUX
- SPECTRAL MEASUREMENTS
- CCT AND CRI
- X,Y,Z COORDINATES
- SCATTERING MEASUREMENTS (BRDF/BSDF)
- 3D SCANNING OF OBJECTS

GONIOPHOTOMETER

The RiGO 801 near-field goniophotometer, described in the EN 13032-1 standard, uses a luxmeter and luminance camera that allow for splitting of a luminous surface into smaller parts. It can measure LIDCs, luminous flux, and the luminance of light-emitting surfaces to enable us to create photometric files (eulumat or IES), measurement reports, and all necessary values for DIALux.

LUMINANCE METER

We use the best handheld spot luminance meters available. Their SLR optical system enables the viewfinder to show the exact area to be measured even at close range, making focusing easy and accurate. Special attention has also been paid to the minimisation of flare to give precise $V(\lambda)$ correlation.

3D SCANNER

The ATOS Compact Scan is easy to use, low weight, and highly flexible.

LUXMETER

The handheld RadioLux 111 is used to make precise photometric and radiometric measurements. It can be equipped with various photometric heads depending on the illumination being measured according to the EN 12464-1 standard. We have heads for spherical, semi-cylindrical, and horizontal illuminance measurements.

LUMINANCE ANALYSER

Evaluation of illuminated areas requires knowledge of the luminance distribution within the whole field of view or in many parts of it. Doing this using many parallel measurements is time-consuming and complex, if possible at all. The luminance analyser is a resolved radiation receiver (CCD matrix camera) that enables complex measurement for glare evaluation, assessment of night road visibility conditions, emission evaluations of glare sources, and the determination of contrast ratios.

SCATTEROMETER

The Mini-Diff 'optical mouse' enables optical designers to capture the scattering properties of a surface to be exported to the appropriate software.

SPECTROMETER

A spectrometer is an instrument that measures the properties of light across a specific part of the electromagnetic spectrum. It is typically used in the spectroscopic analysis and identification of materials. The most measured parameter is light intensity but other measurement possibilities include polarisation states.

INTEGRATING SPHERE

Integrating spheres enable the evaluation of a light source's luminous flux based on measurement of indirect luminance within the sphere using omnidirectional and unidirectional measurements.



THERMAL TESTS & MEASUREMENTS

OPTICAL TESTS & MEASUREMENTS

THERMAL TESTS & MEASUREMENTS

ELECTRICAL & ELECTRONIC TESTS & MEASUREMENTS

MECHANICAL TESTS & MEASUREMENTS

Our thermal laboratory is equipped with a thermal chamber, climate chamber, glow wire tester, needle flame tester, thermal camera, hot winding ohmmeter, and many more devices. In the hands of our professional engineers, such equipment can easily check the thermal performance of products and provide a large number of tests and measurements.

AVAILABLE TESTS

- HIGH TEMPERATURE OPERATING LIFETIME (HTOL)
- LOW TEMPERATURE OPERATING LIFETIME (LTOL)
- HIGH/LOW TEMPERATURE STORAGE LIFETIME
- GLOW WIRE TESTING IN °C
- TEMPERATURE CYCLING
- POWER CYCLING

PRODUCT RELIABILITY

Mechanical stress caused by temperature fluctuations can have a profound effect on a product's reliability and lifetime, and although the operation of a product will not normally undergo extreme changes in temperature, it is always a possibility. It is important to understand the effects of that mechanical stress in order to verify and, if necessary, improve the design of the final product.

FAILURE RATE

Any product can fail due to unforeseen circumstances or simply due to minor or hidden faults in components or even operation. However, even though failure rates are an inevitable parameter, we try to keep them to a minimum. By measuring the failure rate of a product, standardly expressed as a percentage, it is possible to assess its robustness and maybe find faults in the design at earlier stages, making the resolution easier, faster, and more cost effective.

LIFETIME PREDICTION

We all want quality products, and a mark of their quality is their predicted lifetime. Lifetimes are also important when it comes to designing a device, or using a device in a larger system, as it affects the final outcome. A product's lifetime is calculated based on the determination of material deterioration and durability, literally, how long the product can last before it is worn out or deemed no longer effective.

EVALUATION OF FLAMMABILITY & FIRE RESISTANCE

For reasons of safety, it is essential to understand the behaviour of components and materials when exposed to open fire or conditions that can cause ignition, such as unexpected heat from surrounding components or even from operation at high temperatures.

INTRINSIC RELIABILITY OF INTEGRATED CIRCUITS

There are many tests that a product must undergo to quantify and evaluate its quality and robustness. One of the most basic tests is that which determines the inherent resistance of the device under test to prolonged operational stress, including both electrical and thermal stress.

THE EFFECT OF STORAGE CONDITIONS

Every product needs to be stored at some point. It is important to understand the effects of various storage conditions on products, specifically on the materials used, which will degrade over time. This test helps us to know how best to protect the items from unnecessary damage and degradation during storage and to define ideal storage conditions.

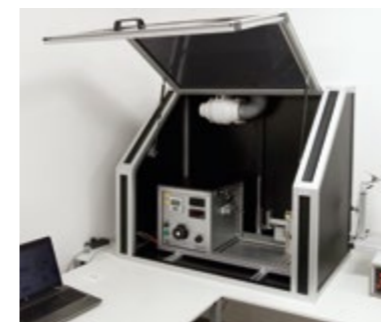
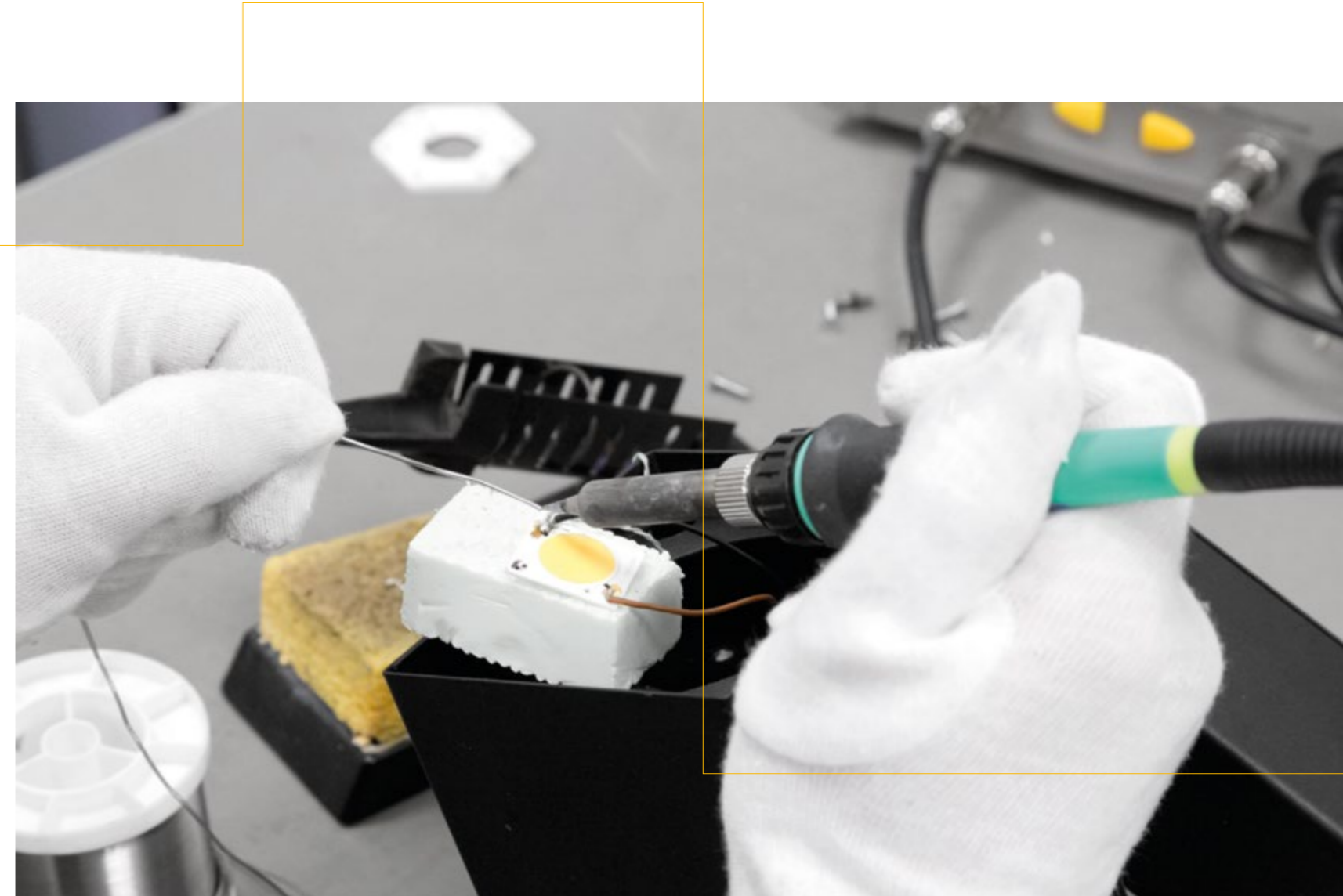

ELECTRICAL & ELECTRONIC TESTS & MEASUREMENTS

OPTICAL TESTS & MEASUREMENTS

THERMAL TESTS & MEASUREMENTS

ELECTRICAL & ELECTRONIC TESTS & MEASUREMENTS

MECHANICAL TESTS & MEASUREMENTS

Electrical devices require the verification of their quality through performance of electrical tests and measurements according to international standards. We can perform the tests required for general classification, marking, and electrical construction and safety evaluation following IEC 60598-1-12/61010/60335. We also offer DALI testing including a DALI conformity report.

AVAILABLE TESTS

- LONG-TERM TESTS ACCORDING TO IEC 60598-1-12
- ELECTRICAL SAFETY TESTS ACCORDING TO IEC 60335/61010
- FUNCTIONAL TESTS
- EMC TESTING
- DALI COMPATIBILITY TESTS

HIGH VOLTAGE (DIELECTRIC VOLTAGE WITHSTAND)

An electrical test performed on a component or product to determine the effectiveness of its insulation. The test may be between mutually insulated sections of a part or energised parts and electrical ground, and is used to qualify a device's ability to operate safely under rated electrical conditions.

INSULATION RESISTANCE

A spot insulation test that uses an applied DC voltage to measure insulation resistance in either k Ω , M Ω or G Ω . The measured resistance is intended to indicate the condition of the insulation or dielectric between two conductive parts – higher resistance means better insulation. Ideally, the insulation resistance would be infinite, but as no insulators are perfect, leakage currents through the dielectric will ensure that a finite resistance value is measured.

FUNCTIONALITY

A test that determines if a device functions properly over a period of a few days under normal operating conditions. If the device fails, no further tests will be performed and the design reconsidered.

EARTH BOND

A test performed by measuring the resistance between the third pin (ground) and outside metal body of the product, intended to ensure a product does not cause an electric shock resulting from insulation failure. It is usually carried out at a slightly higher current (e.g. 25–60 A) so that the ground bond circuit maintains safe voltages on the chassis of the product even at a high current.

LEAKAGE CURRENT

Leakage current is the current that flows through the protective ground conductor to ground. In the absence of a grounding connection, it is the current that could flow from any conductive part or the surface of non-conductive parts to ground if a conductive path was available, such as a human body.

FREQUENT SWITCHING

This test determines the effects of frequent switching on and off of the power supply to the device under normal operating conditions. If the device turns on each time, it passes the test.

UNDER-VOLTAGE

The device is supplied with a lower than nominal supply voltage. It passes the test when able to operate under these conditions for a defined period of time.

OVER-VOLTAGE

The device is supplied with an above nominal supply voltage. It passes the test if it can function under these conditions for a defined period of time.

ENDURANCE (IEC 60598-1-12)

The device is supplied with a voltage 1.1 times higher than nominal in ten cycles of 21 hours of operation and 3 hours of no operation. If the device still functions after this, it passes the test.

DIMMING (DALI, 0–10 V, 1–10 V)

It is important to understand the response of the device under test to various dimming protocols.

LIFETIME PREDICTION

This test operates the device under normal conditions for an extended period to induce and measure the degradation of electrical and optical parameters.

DALI COMPATIBILITY TEST & CONFORMITY REPORT

We have our own DALI tester, which enables us to perform DALI testing in-house. As a regular member of DALI, positively tested devices can be sent directly to DALI WG for certification.

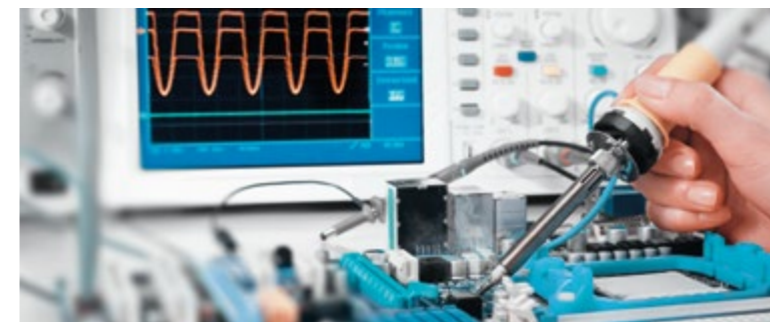

MECHANICAL TESTS & MEASUREMENTS

OPTICAL TESTS & MEASUREMENTS

THERMAL TESTS & MEASUREMENTS

ELECTRICAL & ELECTRONIC TESTS & MEASUREMENTS

MECHANICAL TESTS & MEASUREMENTS

All luminaires must undergo a series of mechanical performance tests according to IEC 60598 safety standards – conformity with which is marked by the ENEC logo. Our internal laboratory capabilities allow us to evaluate mechanical performance in-house during product development as well to offer comprehensive testing and measurement services to customers.

AVAILABLE TESTS

- WATER/DUST PROTECTION (IP)
- IMPACT PROTECTION (IK)

WATER/DUST PROTECTION (IP)

The IP rating given to a luminaire (or other device) expresses its ability to withstand penetration by foreign bodies or liquid. The code consists of two numbers: the first representing the degree of protection against ingress by anything from a hand to fine particles of dust, and the second representing the degree of protection against ingress by a liquid. We measure the effects of rated exposures and provide an appropriate IP rating. Our testing devices allows us to do measurements up to IP67.

IMPACT PROTECTION (IK)

The IK rating given to a luminaire (or other device) expresses the ability of the cover to withstand and protect the device contents from mechanical impact. A pendulum hammer is used during the testing procedure to carry out a series of impacts according to the EN 60068-2-75 standard. The given rating is applicable to the whole cover unless individual parts are separately rated and labelled. The rating system works in a similar way to the IP system, using a code with two numbers to indicate impact resistance, with '00' indicating no resistance and '10' representing resistance to an impact energy of 20 Joules (J). Our testing devices allows us to check IK up to IK06 (1 J).

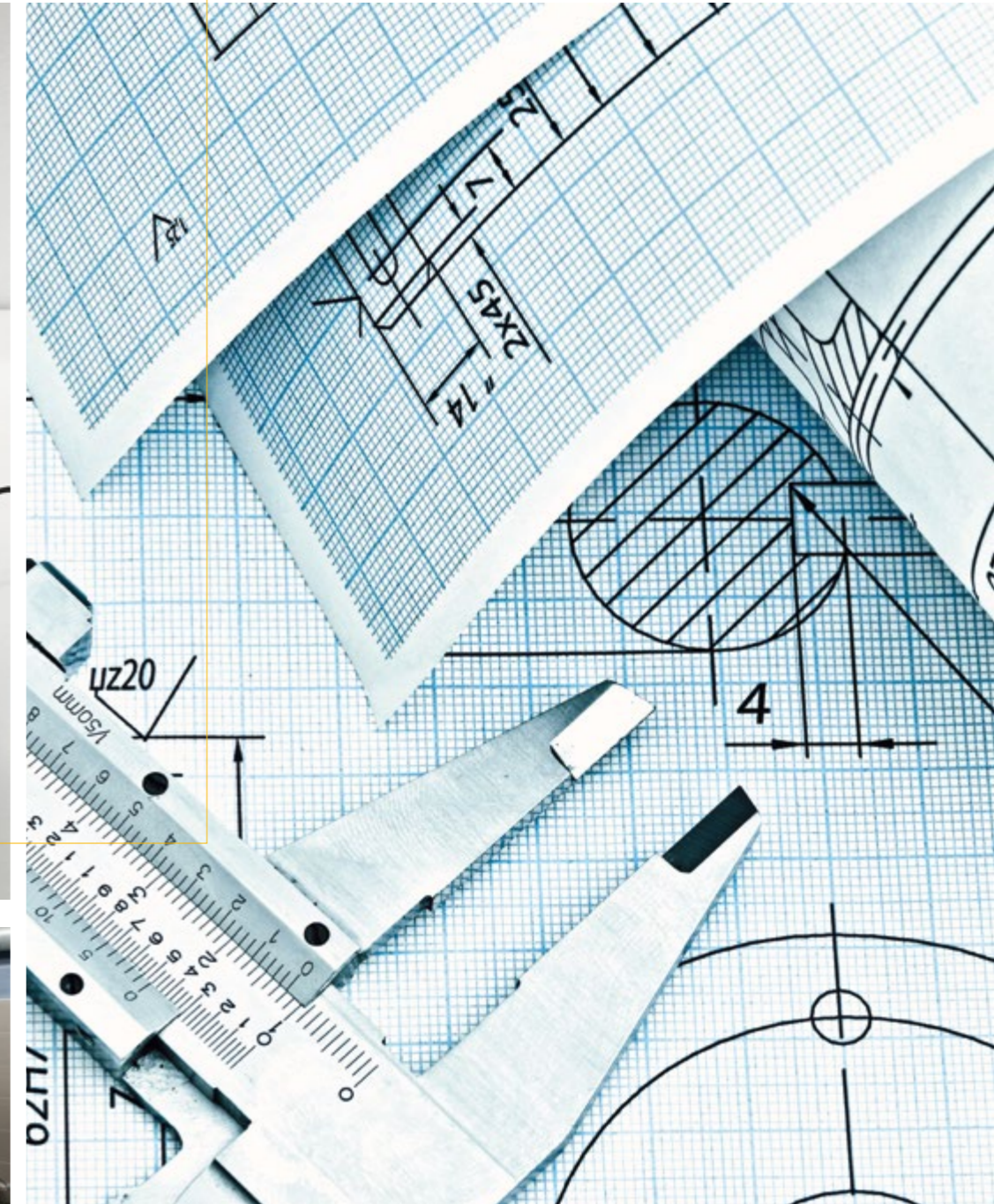

THE LONG-TERM TEST LAB

The use of Solid State Lighting (SSL) technology continues to grow rapidly, and LED-based luminaires bring new challenges in testing and characterisation. Modern SSL luminaires offer additional capabilities in the control of light properties in comparison with conventional light sources. Therefore, the complexity of electronic design is much higher, and so also the demands on testing.

THE LONG-TERM TEST (LTT) LAB KEY FEATURES

We have developed an automated long-term testing system, the LTT lab, that can test the light output and electrical parameters such as input current, voltage, apparent power, active power, reactive power, and power factor, of 6 LED-based luminaires simultaneously. With up to 9 thermocouples per channel, we can check even large luminaires. In addition, we can also test the dimming functionality of luminaires using analogue or DALI dimming. We use this testing system during the final stages of luminaire development as part of final characterisation, the results of which are included in such materials as datasheets.

Since both the hardware and software are developed by iLumTech, the functionality of the LTT lab can be extended and adjusted to upcoming new test regulations and requirements.

- The light emitted by the luminaires under test is measured by sensors that detect relative lumen output.
- Luminaires are powered by programmable linear power supplies that ensure stable and high quality power supply and offer the possibility to simulate power line abnormalities.
- The combined input power of all luminaires under test is limited to 500 W.

LTT LAB CAPABILITIES

- Functionality test
- Frequent switching test
- Under-voltage test
- Over-voltage test
- Endurance test (IEC60598-1-12)
- Dimming test (DALI, 0–10 V, 1–10 V)
- Lifetime test

DALI APPROVAL

We have been a regular member of DALI since 2012 and actively participated in each DALI group meeting since the group's establishment. This gives us the opportunity to influence the DALI standard itself and also certification conditions for new products.

HOW IT WORKS AND WHY WE CAN APPROVE USE OF THE LOGO

A DALI network consists of DALI-compatible controllers and one or more lighting devices such as drivers, dimmers, user-interfaces, sensors, and much more. The protocol allows for all of these devices to be addressed and controlled using individual, group, and scenic commands. Control possibilities include dimming, Tunable White regulation, RGB lighting, the addition of sensors, creation of both static and dynamic sequences, and even system monitoring.

DALI's digital simplicity and flexibility enables the creation of solutions that are easy-to-use, robust, interoperable, and above all affordable. DALI has proven its reliability for many years, and will continue to develop and support the growing demands for professional lighting.

In 2014, a new logo and licensing process was agreed to define the conditions for proper usage of the DALI logo. Each new product must pass testing by an official DALI tester. Thanks to having our own DALI tester, we can perform DALI testing in-house. The basic DALI tester configuration can be extended for further testing, meaning we can provide even stricter testing than that required by the standards. We intend to become an official DALI testing house to simplify and shorten the DALI certification process for our customers.

If you want the DALI trademark to be applied to any developed product or device, you must ask a member of DALI WG. As an active member, we have approval to use the logo on developed products that are compliant with the latest DALI standard. Furthermore, membership gives us direct access to the newest version of test sequences and standards, thus ensuring the most up-to-date testing conditions.



THE APPROACH YOU TRULY DESERVE

Our services and products are built around your needs and wishes. Everything else is just general guidance. Let us know what you need, how we can support you, and where you can utilise our capabilities. Feel free to contact us with any question and benefit from our fast responses, flexibility, and customer-oriented principles.

EXPERIENCED ENGINEERS

Our engineers have experience in every field related to the development of lighting devices and their parts.

FULLY EQUIPPED R&D

We have some of the best-equipped optical, thermal, electronic, and mechanical laboratories in Europe.

FUTURE ORIENTED THINKING

Thanks to our experience of the LED industry, all our development and engineering is done with the future in mind.

PROFESSIONAL OUTPUTS

Technical documentation and measurement reports are professionally completed and compiled ready for CE certification and entrance into serial production.

CONFIDENTIAL ATTITUDE

We have an NDA approach to all our work. The confidentiality of information about our cooperation and the projects we work on together is an essential part of our service.

CONTINUOUS SERVICE

Product development is a never-ending process. We will continue with you on this journey through optimisations, updates, and customisations.



PROVIDING THE PERFECT SOLUTION IS NOT JUST OUR JOB. IT IS OUR PASSION.





HEAD OFFICE
iLumTech
906 02 Dojč 419
Slovakia
Email: info@ilumtech.eu
www.ilumtech.eu